

Title: (Digital-TM-Block-Logo-72pt.eps)
Creator: Adobe Illustrator(TM) 3.2
CreationDate: (3/31/93) (10:24 AM)

Prioris™ ZX 6000MP Server Powergrade Kit

Installation Guide

Order Number: ER-93UAB-IA. A01

Digital Equipment Corporation

August 1996

The information in this document is subject to change without notice and should not be construed as a commitment by Digital Equipment Corporation.

Restricted Rights: Use, duplication, or disclosure by the U.S. Government is subject to restrictions as set forth in subparagraph (c) (1) (ii) of the Rights in Technical Data and Computer Software clause at DFARS 252.227-7013.

FCC Note: This equipment has been tested and found to comply with the limits for a Class B digital device, pursuant to Part 15 of the FCC rules. These limits are designed to provide reasonable protection against harmful interference in a residential installation. Any changes or modification made to this equipment may void the user's authority to operate this equipment.

This equipment generates, uses, and can radiate radio frequency energy and, if not installed and used in accordance with the instructions, may cause harmful interference to radio and television reception; however, there is no guarantee that interference will not occur in a particular installation. If this equipment does cause harmful interference to radio or television reception, which can be determined by turning the equipment off and on, the user is encouraged to try to correct the interference by one of the following measures:

- Re-orient or relocate the receiving antenna.
- Increase the separation between the equipment and the receiver.
- Connect the equipment to an outlet on a circuit different from that to which the receiver is connected.
- Consult the dealer or an experienced radio/TV technician for help.

DO NOT attempt to modify this equipment. If modified, the FCC may void your authority to operate this equipment.

Canadian Department of Communications Statement

This Class B digital apparatus meets all requirements of the Canadian Interference Causing Equipment Regulations.

Prioris, DEC, DECpc, and the DIGITAL logo are trademarks of Digital Equipment Corporation. Intel and Pentium are registered trademarks of Intel Corporation. MS-DOS is a registered trademark of Microsoft Corporation. All other trademarks and registered trademarks are the property of their respective holders.

© 1996 Digital Equipment Corporation.
All Rights Reserved.



Contents

Introduction	1
Kit Contents	1
Tools Needed	2
Update Your BIOS	2
Power Down the Server	2
Check the Switch Settings	3
Replace the Panel and Reconnect the Cables	4
Power Up the Server and Update Your BIOS	4
Powergrade Installation	4
Power Down the Server	4
Installing a Second CPU Module	5
Installing a New Memory Module	6
Install the New Medallion	6
Replace the Panels and Reconnect the Cables	6
Run the System Configuration Utility (SCU)	7
Troubleshooting	8
Using the Crisis Recovery Diskette if Necessary	8
Accessing the Bulletin Board	8

Figures

Figure 1 Main Logic Board	3
Figure 2 Installing a Second CPU Module.....	5

Conventions

Symbol	Meaning
	NOTE: Provides general information.
	CAUTION: Provides information to prevent damage to equipment.
	WARNING: Indicates the presence of a hazard that can cause personal injury if the hazard is not avoided.



NOTE: You may lose data if you have not backed up your system. If you do not wish to install this kit yourself, contact Digital Customer Service. For a nominal fee, a Customer Service Technician can install it for you.

Prioris™ ZX 6000MP Server

Powergrade Kit

Introduction

Thank you for purchasing a Prioris™ ZX6000 MP Powergrade Kit. This Powergrade kit contains all the components and instructions required to upgrade your CPU configuration to either two *Intel® Pentium®* CPUs operating at 166 MHz or at 200 MHz. The instructions to install a memory upgrade kit are also included.

Kit Contents

The Prioris ZX Powergrade kits and memory upgrade kits contain:

Powergrade Kit	FR-PC93U-AA	FR-PC93U-AB
CPU board with 2 <i>Pentium®</i> 166 MHz (P6166) CPUs	✓	
CPU board with 2 <i>Pentium®</i> 200 MHz (P6200) CPUs		✓
PCB retainer assembly	✓	✓
SCU diskette	✓	✓
Antistatic wrist strap	✓	✓
Prioris ZX medallion (product name)	✓	✓
Memory Upgrade Kit	FR-PC93U-MA	
Memory module (<i>for memory > 384 MB</i>)		2
PCB retainer assembly		2

Tools Needed

- Phillips screwdriver, 1 pt.
- Antistatic wrist strap (supplied)

Update Your BIOS

A diskette containing the required BIOS (Basic Input-Output System) software may be included with the Powergrade kit. BIOS is software that is in a nonvolatile read-only memory (ROM) chip, which is on the main logic board of your computer. The BIOS has several functions, including initializing hardware and booting the operating system when the computer is turned on.

If a BIOS diskette is included, you **must** install the new BIOS before installing your Powergrade kit. When updating the BIOS, you must also remove any video option card. This will enable the onboard VGA.



NOTE: If a BIOS upgrade is not needed, a BIOS upgrade diskette is not included with the Powergrade kit. Continue with the Powergrade Installation, page 4.

Power Down the Server

1. Turn off your server.
2. Disconnect any external devices, the **ac power cord**, and the monitor power cord.
3. Unlock the security lock at the back of the server.
4. Remove the left side panel by sliding it toward the rear of the system.



WARNING: You might injure yourself or damage your server if you attempt to remove the side panel before unplugging the ac and monitor power cords.

5. Remove any Video Option card if installed.

Check the Switch Settings

Make sure that the following switches are enabled:

J35-SW1	On	BIOS upgrade	Enabled (On) (Figure 1)
J35-SW3	On	Boot Block update	Enabled (On)
J35-SW7	On	CPU bus speed	The 66 MHz setting is for either a 166 MHz or a 200 MHz CPU.

ON = switch closed; OFF = switch open

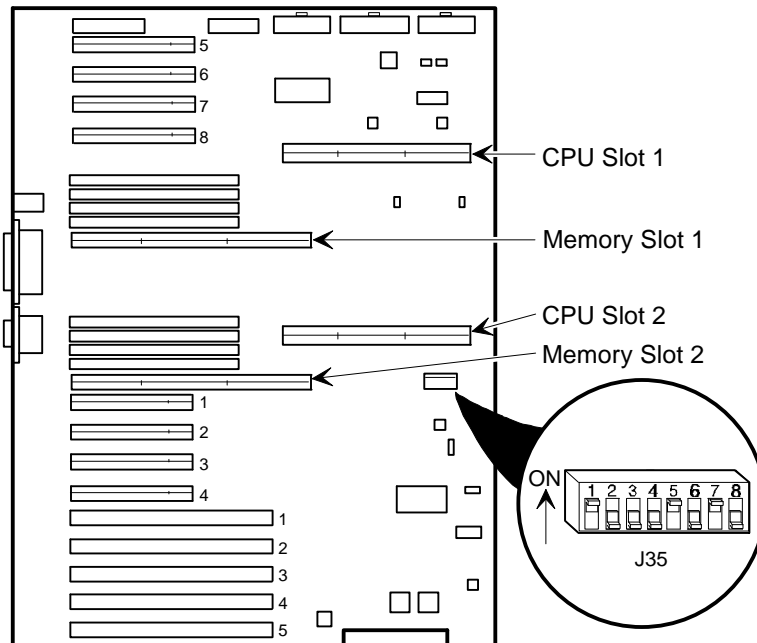

DEC00692-9

Figure 1. Main Logic Board

Replace the Panel and Reconnect the Cables

1. Install the left side panel.



NOTE: The server will not power up with the side panel removed.

2. Connect the cables, the monitor power cord, and the server power cord to the back of the server.

Power Up the Server and Update Your BIOS

1. Turn on your server and allow the POST to complete.
2. Insert the startup utilities diskette.
3. At the MS-DOS prompt, change the directory to A:\UPGRADE and type:
PHLASH
4. Press Enter to continue. PHLASH automatically updates your server's BIOS, and after the flashing process completes, the server automatically reboots itself.
5. Remove the startup utilities diskette.

Powergrade Installation

Power Down the Server

1. Turn off your server.
2. Disconnect any external devices, the **ac power cord**, and the monitor power cord.
3. Unlock the rear security lock of the server.
4. Remove the left side panel by sliding it toward the rear of the system.
5. If you updated your BIOS, remember to return J35-SW1 and SW3 to Off (Figure 1) to protect your BIOS boot block from being modified.



CAUTION: Static electricity can damage electronic components. Before handling or installing any electronic device, use the wrist strap and discharge all static electricity from your body by connecting the ground clip to an exposed metal surface of your computer's chassis.

Installing a Second CPU Module

If you are installing a second CPU module, use the following procedure:

1. Install the second CPU module in the lower CPU slot on the main logic board (Figure 1).
2. Secure this CPU module to the main logic board using the retaining bracket from the Powergrade kit.

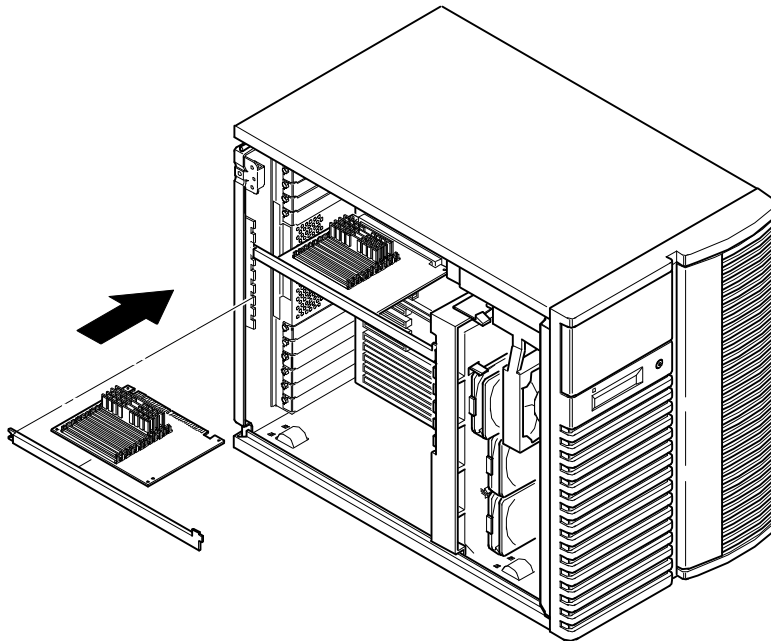

Figure 2. Installing a Second CPU Module

Installing a New Memory Module

If you are installing a memory module, install it in memory module Slot 2 (located right under memory module slot 1). See Figure 1.

Use the label, located on the inside of the side panel, to determine the slot location.



NOTE: Completely fill the primary memory module (Memory Module 1) before installing a second memory module (Memory Module 2).

Install the New Medallion

Install the new medallion (product nameplate). This nameplate is press-fit into the left-front door. Replace the nameplate to identify your server to service personnel. To replace the nameplate:

1. On the inside of the door, push out the old nameplate by carefully pressing on the two green plastic posts with the Phillips screwdriver.
2. Press the new nameplate into place.

Replace the Panel and Reconnect the Cables

1. Install the left side panel and lock the server.



NOTE: The server will not power up with the side panel removed.

2. Connect the cables, the monitor power cord, and the server power cord to the back of the server.

Run the System Configuration Utility (SCU)

The SCU enables you to check or change your server's configuration. Run the SCU to configure your server for the new CPU chip or module.

To start and run the SCU:

1. Insert the SCU diskette into drive A and turn on your server. The diskette should boot automatically from the diskette.
2. When the SCU title appears, press any key to continue. Afterwards, follow the instructions on your screen to access the SCU main menu.
3. From the main menu, press the up or down arrow to highlight an item and then press Enter to select it. Press F1 at any time for help about a selection.
4. From the main menu select `Configure Computer` and then `View and Edit Details`.
5. Select `Save and Exit` to configure your server for the CPU module.
6. When complete, remove the SCU diskette from drive A and reboot your server.

Refer to Chapter 2, "Server Utilities," in your computer user's guide for any additional information on running the SCU.

Troubleshooting

Using a Crisis Recovery Diskette if Necessary

If your Powergrade kit includes a Crisis Recovery diskette, it is used only if your computer's BIOS fails or if a BIOS upgrade is unsuccessful.



NOTE: If a BIOS upgrade is not needed, a Crisis Recovery diskette is not included in the Powergrade kit.

To use a Crisis Recovery diskette:

1. Turn off the server and remove the power cables and the side panel to access the Main Logic board.
2. Set J35-SW2 to ON to enable Recovery mode.
3. Remove any Video Option Card to enable the onboard VGA.
4. Replace the side panel and reconnect the power cables.
5. Insert the Crisis Recovery diskette into drive A and reboot the computer.



NOTE: Remember to set switch J35-SW2 to OFF (Normal mode) after using the Crisis Recovery diskette.

Accessing the Bulletin Board

For future reference, you can access product information and software updates using the Internet at:

<http://www.pc.digital.com>

<http://www.pc.digital.com/~ftp>

You can also access software updates through Digital's Bulletin Board Service (BBS) by calling in the United States **508-496-8800**.

The BBS is **not** a source for technical support. For advice, please call your local Digital Service Representative.