

# DIGITAL Personal Workstation

---

## Service Maintenance Manual

Part Number: ER-D4BWW-SM. A01

**May 1998**

---

The information in this document is subject to change without notice and should not be construed as a commitment by Digital Equipment Corporation.

Digital Equipment Corporation assumes no responsibility for any errors that might appear in this document.

The software described in this document is furnished under a license and may be used or copied only in accordance with the terms of such license. No responsibility is assumed for the use or reliability of software or equipment that is not supplied by Digital Equipment Corporation or its affiliated companies.

Restricted Rights: Use, duplication, or disclosure by the U.S. Government is subject to restrictions as set forth in subparagraph (c) (1) (ii) of the Rights in Technical Data and Computer Software clause at DFARS 252.227-7013.

*DIGITAL Personal Workstation Service Maintenance Manual*  
Copyright © Digital Equipment Corporation.  
All Rights Reserved.

AGP is a registered trademark of Intel.

DEC, DIGITAL PC, and the DIGITAL logo are registered trademarks of Digital Equipment Corporation.

Intel, Pentium, and Pentium II are registered trademarks of Intel Corporation.

Microsoft and Windows NT are registered trademarks of Microsoft Corporation.

Permedia 3D Labs is a registered trademark of 3D Labs.

All other trademarks and registered trademarks are the property of their respective holders.

## FCC Notice

This equipment has been tested and found to comply with the limits for a Class B digital device, pursuant to Part 15 of the FCC rules. These limits are designed to provide reasonable protection against harmful interference in a residential installation.

Any changes or modifications made to this equipment may void the user's authority to operate this equipment.

This equipment generates, uses, and can radiate radio frequency energy and, if not installed and used in accordance with the instructions, may cause harmful interference to radio communications. However, there is no guarantee that interference will not occur in a particular installation. If this equipment does cause harmful interference to radio or television reception, which can be determined by turning the equipment off and on, the user is encouraged to try to correct the interference by one or more of the following measures:

- Reorient or relocate the receiving antenna
- Increase the separation between the equipment and receiver
- Connect the equipment into an outlet on a circuit different from that to which the receiver is connected
- Consult the dealer or an experienced radio/TV technician for help

The user may find the following booklet prepared by the Federal Communications Commission helpful: How to Identify and Resolve Radio-TV Interference Problems. This booklet is available from the U.S. Government Printing Office, Washington, D.C., 20402. Stock No. 004-00398-5.

All external cables connecting to this basic unit need to be shielded. For cables connecting to option boards, see the option manual or installation instructions.

## Canadian DOC Notice

This digital apparatus does not exceed the Class B limits for radio noise emissions set out in the radio interference regulations of the Canadian Department of Communications.

## VCCI Notice

This is a class B product based on the standard of the Voluntary Control Council for Interference by Information Technology Equipment (VCCI). If this equipment is used in a domestic environment, radio disturbance may arise. When such trouble occurs, the user may be required to take corrective actions.

## German Ergonomic Notice

This equipment meets or exceeds the ergonomic requirements of ZH1/618 and is certified to bear the GS mark by TUV Rheinland of Germany.

## Safety Requirements

This equipment meets or exceeds requirements for safety in the U.S. (UL 1950), Canada (CSA C22.2 No. 950), and Europe (EN 60950/IEC 950) with Nordic requirements.



**WARNING:** There is a danger of battery explosion if a lithium battery is incorrectly replaced. To prevent damage to your computer, be sure the + side faces up when installing a new battery. Also, be sure you replace the battery with either a DIGITAL (P/N 12-41474-05), Toshiba (P/N CR2032), or equivalent 3 V dc lithium battery.

Depending on your locality, your computer's battery might be considered hazardous waste. Make sure you follow any state or local statute to properly dispose of the old battery.



**ADVARSEL:** Der er fare for, at et lithiumbatteri eksploderer, hvis det udskiftes ukorrekt. Undgå, at beskadige din computer - HUSK, at + siden skal vende opad, når du installerer et nyt batteri. Du skal udskifte batteriet med enten et DIGITAL (delnummer 12-41474-05), Toshiba (delnummer CR2032), eller tilsvarende 3 V jævnstrøms lithiumbatteri.

Afhængig af dit lokalområde, er det muligt, at din computers batteri betragtes som farligt affald. Husk, at følge evt. miljølove og lokale bestemmelser, når du kasserer det gamle batteri.



**VAROITUS:** Litiumpatterit voivat räjähtää, jos ne asennetaan väärin. Estääksesi tietokoneesi vaurioitumisen varmista, että patteria asentaessasi sen positiivinen (+) puoli on ylöspäin. Tarkista myös, että käyttämäsi uusi patteri on joko DIGITAL (osa no. 12-41474-05), Toshiba (osa no. CR2032) tai vastaavanlainen 3 voltin tasavirtalitiumpatteri.

Asuinpaikastasi riippuen tietokoneesi patteria voidaan pitää ongelmajätteenä. Pidä huoli, että hävität vanhan patterin voimassa olevien lakien ja asetusten mukaisesti.



**WARNING!** Det kan förekomma en batteriexplosion om ett litium-jonbatteri byts ut på felaktigt sätt. Förhindra att datorn skadas genom att se till att plussidan (+) är uppåtvänd när du sätter i ett nytt batteri. Det gamla batteriet får endast bytas ut mot ett DIGITAL-batteri (artikelnummer 12-41454-05), ett Toshiba-batteri (artikelnummer CR2032) eller ett motsvarande litiumbatteri på 3 volt likström.

Datorbatterier anses vara miljöfarligt avfall i många länder. Du måste följa alla lokala bestämmelser när du avyttrar ett gammalt batteri.

## **Laser Safety Notices**

All CD-ROM drives included in DIGITAL Personal Workstations are classified as Class 1 laser products and comply with safety standards as set by U.S. government and applicable European agencies.

No hazardous radiation is emitted from this CD-ROM drive; the laser beam is completely enclosed in the CD-ROM subassembly during all customer operation and maintenance. In the event that repair or service of the CD-ROM subassembly is required, only authorized DIGITAL service personnel should perform such repairs.

# Contents

<b>Preface</b> .....	vi
<b>1</b>	
<b>Product Description</b>	
Introduction .....	1-1
DIGITAL Personal Workstations with Windows NT 4.0.....	1-3
Related Material .....	1-4
Latest Product Information and Updates.....	1-5
<b>2</b>	
<b>BIOS Setup Utility</b>	
Running the BIOS Setup Utility .....	2-1
Helpful Hints .....	2-2
BIOS Setup Utility Options.....	2-3
Main.....	2-4
Advanced.....	2-8
Security Options .....	2-13
Power.....	2-15
Boot .....	2-16
Flash Utility .....	2-17
<b>3</b>	
<b>System Software</b>	
Introduction .....	3-1
Configuring System Parameters .....	3-2
Configuring Video .....	3-2
Configuring Networking.....	3-2
Configuring Additional Hardware.....	3-2

## Contents

DIGITAL Supplied Software .....	3-3
Applications .....	3-4
DIGITAL On-Line Documentation .....	3-5
Operating System Kit .....	3-6
DIGITAL System Software CD.....	3-6
ClientWORKS .....	3-7
Using Diagnostics.....	3-8
Windows NT Diagnostics .....	3-8
DOS-based Diagnostics.....	3-8
Restoring Your Software.....	3-10
DIGITAL System Software CD Installation Program.....	3-11

## 4

### Troubleshooting

Initial Troubleshooting.....	4-1
Pass/Fail Criteria .....	4-3
Diagnostics .....	4-4
ClientWORKS and DMI .....	4-5
Self-Monitoring, Analysis, and Reporting Technology (S.M.A.R.T).....	4-6
Advanced Troubleshooting .....	4-7
Workstation Troubleshooting .....	4-8
Disk Drive Troubleshooting.....	4-22
Monitor Troubleshooting .....	4-24
Audio Troubleshooting.....	4-26
CD-ROM Troubleshooting .....	4-28
Network Interface Troubleshooting .....	4-29
Error Messages.....	4-30
POST Messages .....	4-30
POST and Boot Messages .....	4-31
POST Error Codes and Beep Codes.....	4-34

## 5

### Parts Replacement

Introduction .....	5-1
DIGITAL Personal Workstation IPB List .....	5-2
Enclosure .....	5-4
Storage Devices .....	5-5
SCSI Adapter Cards .....	5-6
Cables and Terminator .....	5-6
Miscellaneous.....	5-7
Service Procedures .....	5-8



## Contents

Recommended Tools .....	5-8
Other Materials Needed.....	5-8
Special Tools Required.....	5-8
Remedial Diagnostic Test Software.....	5-9
Virus Software Information.....	5-9
BIOS and Driver Information.....	5-9
Disconnecting External Devices and Power .....	5-9
Removing the Workstation's Outside Cover .....	5-10
Workstation Components .....	5-12
Main Logic Board Components.....	5-12
Main Logic Board Connectors (Rear Panel).....	5-14
Main Logic Board Feature Switch Settings.....	5-16
Pentium II Processor Module Switch Settings.....	5-18
Adding Additional Workstation Memory.....	5-19
Adding Video Memory .....	5-21
Removing and Replacing Components .....	5-23
Removing the Main Logic Board .....	5-24
Removing the DIMMs .....	5-26
Removing the Lithium Battery.....	5-28
Removing the Processor Module .....	5-30
Removing the Voltage Regulator Module (VRM).....	5-31
Removing the Terminator Module.....	5-33
Removing the AGP Graphics Accelerator Board .....	5-35
Removing Expansion Boards.....	5-36
Removing the Power Supply.....	5-38
Removing the Control Panel Assembly and Cable.....	5-40
Removing the Option Card Assembly.....	5-42
Removing the Wire Assembly, Headphone/Microphone .....	5-44
Removing the Front Bezel Door.....	5-46
Removing the Front Bezel .....	5-48
Removing a 3½-Inch Device from Front Bay.....	5-50
Removing a 5¼-Inch Device.....	5-52
Removing an Internal 3½-Inch Device.....	5-54
IDE Drive Connections.....	5-56
SCSI Drive Connections .....	5-58
Removing the Diskette Drive.....	5-60
Diskette Drive Connections.....	5-62

Contents

**6**

**Device Mapping**

Introduction .....	6-1
Full Range Processor Memory Address Map .....	6-2
I/O Address Map .....	6-3

**A**

<b>Service Notes</b> .....	A-1
----------------------------	-----

## Contents

### Figures

5-1. DIGITAL Personal Workstation.....	5-3
5-2. Removing the Outside Cover.....	5-11
5-3. Main Logic Board Components.....	5-13
5-4. Main Logic Board Components (Rear Panel) .....	5-15
5-5. Main Logic Board Switch Locations .....	5-17
5-6. Pentium II Processor Module Switch Locations .....	5-19
5-7. DIMM Socket Locations.....	5-20
5-8. Video Memory Socket Location .....	5-22
5-9. Removing the Main Logic Board.....	5-25
5-10. Removing DIMMs.....	5-27
5-11. Removing the Lithium Battery.....	5-29
5-12. Removing the Pentium II Processor Module.....	5-30
5-13. Removing the VRM.....	5-32
5-14. Removing the Terminator Module.....	5-34
5-15. Removing an AGP Graphics Accelerator Expansion Board .....	5-35
5-16. Removing Expansion Boards.....	5-37
5-17. Removing the Power Supply.....	5-39
5-18. Removing the Control Panel Assembly and Cable .....	5-41
5-19. Removing the Option Card Assembly.....	5-43
5-20. Removing the Wire Assembly, Headphone/Microphone .....	5-45
5-21. Removing the Front Bezel Door.....	5-47
5-22. Removing the Front Bezel.....	5-49
5-23. Removing a 3½ -inch Device from the Front Bay .....	5-51
5-24. Removing a 5¼-Inch Device.....	5-53
5-25. Removing an Internal 3½-Inch Device.....	5-55
5-26. IDE Device Data Cable Connections .....	5-57
5-27. SCSI Device Data Cable Connections .....	5-59
5-28. Removing the Diskette Drive.....	5-61
5-29. Diskette Device Data Cable Connections .....	5-63

# Preface **P**

---

This *Service Maintenance Manual* is a troubleshooting guide that can be used for reference when servicing DIGITAL Personal Workstations.

DIGITAL reserves the right to make changes to this *Service Maintenance Manual* without notice. Accordingly, the illustrations and procedures in this document might not apply to all DIGITAL Personal Workstations to be serviced since many of the diagnostic tests are designed to test more than one product.



**CAUTION:** DIGITAL recommends that only A+ certified engineers attempt to repair this equipment. All troubleshooting and repair procedures are detailed to support subassembly/module level exchange. Because of the complexity of the individual boards and subassemblies, no one should attempt to make repairs at the component level or make modifications to any printed circuit board. Improper repairs can create a safety hazard. Any indications of component replacement or circuit board modifications might void any warranty or exchange allowances.

## Preface

# Product Description **1**

---

## Introduction

DIGITAL Personal Workstations are high-performance workstations featuring the latest in computing technology. They can be used as stand-alone computers, as clients, or as servers in a network environment. Developed using the following state-of-the-art technology, these workstations are the most value packed workstations in their class.

- *Microprocessor*— Single or dual Pentium II with 100 MHz bus
- *Memory*— 64 MB standard, expandable up to 1 GB, using 256 MB registered DIMMs
- *Plug and Play*— Optional Plug and Play compatible expansion boards are automatically configured for easy installation.
- *PCI local bus*— The workstation's PCI architecture represents the latest in local bus technology.
- *Video expansion board*— Video expansion board that supports 2D/3D performance. Also contains built-in video playback acceleration to enhance multimedia applications.
- *Onboard Ethernet*— Single-chip DIGITAL 21143 PCI Ethernet LAN controller with 10/100Base-T interface and support for IEEE 802.3 auto-negotiation.

## Product Description

- *Onboard audio*— 16-bit stereo sound circuit supports business and SoundBlaster Pro applications. The internal workstation speaker is connected to the audio system with volume control (selected in the BIOS Setup utility) as the default output device.
- *SCSI adapter*— 16-bit ultra-wide SCSI (UW-SCSI) adapter that supports 68-pin wide, and 68-pin ultra-wide SCSI devices.

## DIGITAL Personal Workstations with Windows NT 4.0

Part Number	Description	Video	HDD	RAM	Additional Features
SN-D4B8W-VC	350i	Permedia 2	4.3 GB ultrawide SCSI	64 MB	1.44MB diskette drive, 32X Atapi CD-ROM, 10/100Base-T Ethernet, 16-bit Audio, SCSI & EIDE controllers, U.S. Country Kit
SN-D4B8W-VD	350i	Permedia 2	4.3 GB ultrawide SCSI	64 MB	1.44MB diskette drive, 32X Atapi CD-ROM, 10/100Base-T Ethernet, 16-bit Audio, SCSI & EIDE controllers, U.S. Country Kit
SN-D4B8W-VA	350i	Permedia 2	no HDD	64 MB	1.44MB diskette drive, 32X Atapi CD-ROM, 10/100Base-T Ethernet, 16-bit Audio, SCSI & EIDE controllers, U.S. Country Kit
SN-D4B8W-VB	350i	Permedia 2	no HDD	256 MB	1.44MB diskette drive, 32X Atapi CD-ROM, 10/100Base-T Ethernet, 16-bit Audio, SCSI & EIDE controllers, U.S. Country Kit
SN-D4B9W-VC	400i	Permedia 2	4.3 GB ultrawide SCSI	64 MB	1.44MB diskette drive, 32X Atapi CD-ROM, 10/100Base-T Ethernet, 16-bit Audio, SCSI & EIDE controllers, U.S. Country Kit
SN-D4B9W-VD	400i	Permedia 2	4.3 GB ultrawide SCSI	64 MB	1.44MB diskette drive, 32X Atapi CD-ROM, 10/100Base-T Ethernet, 16-bit Audio, SCSI & EIDE controllers, U.S. Country Kit
SN-D4B9W-VA	400i	Permedia 2	no HDD	64 MB	1.44MB diskette drive, 32X Atapi CD-ROM, 10/100Base-T Ethernet, 16-bit Audio, SCSI & EIDE controllers, U.S. Country Kit
SN-D4B9W-VB	400i	Permedia 2	no HDD	256 MB	1.44MB diskette drive, 32X Atapi CD-ROM, 10/100Base-T Ethernet, 16-bit Audio, SCSI & EIDE controllers, U.S. Country Kit



## Product Description

## Related Material

The following related material is available:

<b>Document Title</b>	<b>Order Number</b>	<b>Description</b>
<i>Service Quick Reference</i>	ER-D4BWW-SR	Provides troubleshooting information that can be used when servicing DIGITAL Personal Workstations.
<i>Quick Setup Guide</i>	ER-K3BWW-IM (Multilanguage) <sup>(1)</sup>	Describes how to initially setup DIGITAL Personal Workstations.
<i>System Reference</i>	ER-D4BWW-UA (English) ER-D4BWW-UJ (Japanese)	Describes how to operate, configure, and upgrade DIGITAL Personal Workstations.
<i>Systems Solutions</i>	ER-PCDSS-UA (English) ER-PCDSS-UM (Multilanguage) <sup>(2)</sup> ER-PCDSS-UJ (Japanese)	Provides end-user troubleshooting should a DIGITAL Personal Workstation fail to operate after initial setup or after installing optional devices.
<i>System Software</i>	ER-K3BWW-GA (English) ER-K3BWW-GM (Multilanguage) <sup>(3)</sup> ER-K3BWW-GJ (Japanese)	Provides information on the operating system, utilities, and device drivers that came with DIGITAL Personal Workstations.
<i>Warranty and Service</i>	ER-PCWAR-CM	Provides warranty information and a listing of phone numbers for technical support.
Backup Media Kit	OC-04J8A-HW	Digital Personal Workstation Backup Media Kit

<sup>(1)</sup> Includes English, French, Italian, German, Spanish, and Japanese.

<sup>(2)</sup> Includes English, French, Italian, German, Spanish, and Brazilian Portuguese

<sup>(3)</sup> Includes English, French, Italian, German, and Spanish

README files come with the factory installed software and on the supplied backup CD-ROM disc. These files contain useful setup, configuration, and operation information. Read this information first.

## Latest Product Information and Updates

Access product information and download the latest BIOS, device drivers, and software updates using the Internet at:

**<http://www.workstation.digital.com>**

1. Choose **Firmware and Drivers** and select the Intel-based System Library.
2. Choose the correct model from the displayed list.
3. From the file list, choose the file to download.

Product Description

# BIOS Setup Utility **2**

---

## Running the BIOS Setup Utility

The BIOS Setup utility enables you to select and store permanently information about the workstation's hardware and software in the battery-backed memory of the CMOS RAM. This information takes effect each time the workstation boots and can be changed any time you run setup.

You should use the BIOS Setup utility if you experience problems with the hard disk or if you need to reconfigure or expand the workstation. In addition, the BIOS Setup utility might need to be used to modify the configuration after adding or removing hardware, or changing workstation settings.



**CAUTION:** The workstation was setup for normal operation at the factory and will operate properly without additional configuring.

It is important for you to read carefully and understand this chapter before attempting to modify the workstation's factory settings. Changing some settings might cause the workstation to operate improperly.

## BIOS Setup Utility

To access the BIOS Setup utility, perform the following steps:

1. Turn on the workstation and allow the Power-On Self Test (POST) to complete.
2. Make a note of any configuration errors listed, and then press [F2] to display the Main menu.
3. Follow the instructions on the monitor screen and any on-line help pop-up screens to configure your workstation.

## Helpful Hints

- Several keyboard keys are assigned to help you select menus and sub-menus, options, change option values, and display help information. These keys are displayed at the bottom of the main menu and from the General Help pop-up screen.
- Item-specific help is available anytime during the setup process and appears at the right of the setup screen when an option is highlighted. This on-line help provides information about a highlighted option.
- Select *Exit Saving Changes* to save all Setup values and exit Setup.
- Select *Exit Discarding Changes* to exit Setup without recording any changes.
- Select *Load Setup Defaults* to set all Setup options to their default values.
- Select *Discard Changes* to restore all CMOS values from the last session.
- Select *Save Changes* to save all selections without exiting Setup.
- Press [Esc] to exit the BIOS Setup utility.

## BIOS Setup Utility Options

The following Help topics list the BIOS options that can be updated or modified by using the BIOS Setup utility, according to the various sub-menus under which they appear.

- Main Menu Options — Sets basic workstation configuration options (time, date, video, etc.).
- Advanced Options — Sets advanced features to increase workstation performance.
- Security Options — Sets passwords and backup data reminders.
- Power Options — Sets power saving options to increase the life of the workstation.
- Boot Options — Sets the boot sequence of the workstation.
- Exit — Provides options for saving changes and leaving the BIOS Setup utility. Refer to “Navigating,” in the BIOS Setup utility, for additional information.



**NOTE:** The following tables list the BIOS Setup Menu options available for DIGITAL Personal Workstations. Note that an “ \* ” that follows an option in the Settings column indicates the factory default setting.

## BIOS Setup Utility

### Main

Menu Fields	Settings	Comments
System time	Current time	Displays the current time.
System date	Current date	Displays the current date.
Language	English*	Language default.
Legacy Diskette A/ Legacy Diskette B	1.44 MB, 3½* 2.88 MB, 3½  Not Installed* 360 KB, 5¼ 1.2 MB, 5¼ 720 KB, 3½	Sets the size and density of diskette drives.
Local Bus IDE adapter	Disabled Both* Primary Secondary	Enables or disables the local bus IDE adapter. Both enables both the primary and secondary adapters. Primary enables only the primary adapter and Secondary enables only the secondary adapter.
System memory	Not user selectable	Displays the amount of base (conventional) memory each time the workstation boots.
Extended memory	Not user selectable	Displays the amount of extended memory each time the workstation boots.

*continued*

Menu Fields	Settings	Comments
<b>IDE Adapter Primary /Secondary Master/Slave</b>		
Type <sup>(1)</sup>	None 1 to 14 Rsrv 16 to 39 User Auto* CD	Selecting 1 to 14 and 16 to 39 automatically fills in the remaining fields in this menu.  Selecting "User" enables the remaining fields to be filled in manually, using the installed hard disk drive's parameters. <sup>(2)</sup>  If a CD-ROM drive is used for the IDE drive, you must select CD. You can select "Auto" for an HDD.
Cylinders <sup>(1)</sup>	0 to 4095	Displays the number of cylinders.
Heads <sup>(1)</sup>	1 to 64	Displays the number of heads.
Sectors/Track <sup>(1)</sup>	0 to 63	Displays the number of sectors/tracks.
Maximum capacity		Displays the maximum capacity of the device.
Multi-sector transfers <sup>(1)</sup>	Disabled 2 sectors 4 sectors 8 sectors 16 sectors Auto	Determines the number of sectors per block for multiple sector transfers.  Auto refers to the size the disk returns when queried.

<sup>(1)</sup> These fields are automatically filled in if the workstation auto-detected an installed hard disk drive.

<sup>(2)</sup> Incorrect settings can cause the workstation to malfunction.

*continued*



## BIOS Setup Utility

Menu Fields	Settings	Comments
LBA control	Disabled Enabled*	Enabling this option causes Logical Block Addressing (LBA) instead of cylinders and heads. Select "Disabled" for IDE hard disk drives that are up to 528 MB in size. When using an IDE drive larger than 528 MB and an operating system that supports LBA, select "Enable." MS-DOS and Windows are examples of operating systems that support LBA.
32-bit I/O	Enabled* Disabled	Enables or disables the 32-bit, hard disk drive data transfer option. Enabling this option speeds up data transfers and ensures that the HDD supports 32-bit I/O transfers.
Transfer mode <sup>(1)</sup>	Standard Fast PIO1 Fast PIO2 Fast PIO3 Fast PIO4 Fast DMA A Fast DMA B Fast DMA F	Selects the method to transfer data to and from the HDD. If you select the user autotype for the HDD, Setup automatically selects the optimum transfer mode.
Ultra DMA transfer mode	Disabled Mode 0 Mode 1 Mode 2	Selects the Ultra DMA method to transfer data to and from the HDD.

<sup>(1)</sup> These fields are automatically filled in if the workstation auto-detected an installed hard disk drive.

*continued*

## BIOS Setup Utility

Menu Fields	Settings	Comments
<b>Boot Options</b>		
Boot time diagnostic screen	Enabled Disabled*	Enables or disables the display of POST messages. When enabled, displays the diagnostic screen whenever the workstation boots.
BIOS update	Enabled Disabled*	When enabled, allows BIOS updates for the next boot. After reboot, this option resets to "Disabled."
<b>Keyboard Features</b>		
NumLock	Auto* On Off	Turns NumLock on or off each time the workstation boots.  If "Auto" is selected, the workstation will turn on NumLock if it detects a numeric keypad.
Key click	Disabled* Enabled	Enables or disables the audible key click feature.
Keyboard auto-repeat rate	2/sec 6/sec 10/sec 13.3/sec 18.5/sec 21.8/sec 26.7/sec 30/sec*	Sets the number of times a second to repeat a keystroke while the key is held down.
Keyboard auto-repeat delay	1/4 sec 1/2 sec* 3/4 sec 1 sec	Sets the delay time after a key is held down before it begins to repeat a keystroke.

## Advanced

Menu Fields	Settings	Comments
Plug & Play O/S	Yes No*	Select "Yes" if using a Plug & Play operating system such as Windows 9x. Otherwise, select "No."
Enable ACPI	Yes No*	ACPI is the Advanced Configuration and Power Interface firmware. ACPI gives power control over a workstation, allowing users to turn the machine off and on and put the machine in standby or sleep mode.  If the workstation is using Windows NT 4.0 (which cannot use ACPI), select "No." Select "Yes" if you are running Windows 98 or Windows NT 5.0.
Reset configuration data	Yes No*	Select "Yes" to clear the system configuration data if it is suspected to be corrupted, which sometimes occurs after a power outage. This option also clears the Plug and Play databases.  After entering the correct settings (or accepting the default settings), the computer switches this setting back to "No."  If it is not necessary to clear system configuration data, leave the setting at "No."
Large disk access mode	DOS* Other	Select "DOS" if a Windows operating system is installed.  Select "Other" if another operating system (such as UNIX) is installed.

*continued*

Menu Fields	Settings	Comments
<b>Cache Memory</b>		
Memory cache	Enabled* Disabled	Enables or disables the processor's internal cache.
Cache system BIOS Area	Write Protect* Uncached	This option enables the system BIOS to be cached in the internal cache and external cache (if installed). This increases workstation performance by allowing BIOS instructions to be executed in cache instead of RAM.  "Write Protect" is the recommended setting.
Cache video BIOS Area	Write Protect* Uncached	This option enables the video BIOS to be cached in the internal cache and external cache (if installed). This increases workstation performance by allowing video BIOS instructions to be executed in cache instead of RAM.  "Write Protect" is the recommended setting.
Cache base 0 to 512K	Write Protect* Uncached Write Through Write Protect	This option sets the cache policy for the external cache memory.  "Write Protect" is the recommended setting for single-processor workstations, providing the best performance.
Cache base 512K to 640K	Write Protect* Uncached Write Through Write Protect	This option sets the cache policy for the external cache memory.  Write Protect is the recommended setting for single-processor workstations. It provides the best performance.
Cache extended memory	Write Back* Uncached Write Through Write Protect	This option sets the cache policy for the caching of system memory over 1 MB.  "Write Protect" is the recommended setting for single processor workstations. It provides the best performance.

*continued*



## BIOS Setup Utility

Menu Fields	Settings	Comments
<b>I/O Device Configuration</b>		
Serial port A	Auto Disabled 3F8, IRQ4* 2F8, IRQ3 3E8, IRQ4 2E8, IRQ3	<p>Enables or disables onboard serial port A at the specified address.</p> <p>Select "Auto" unless interrupts IRQ4 and/or IRQ3 are allocated as a computer resource.</p> <p>Two devices cannot share the same IRQ. Choosing "Disabled" makes serial port 1 unusable. If selecting "Auto," Setup configures COM1 to address = 3F8h and IRQ = 4 if they are available.</p> <p>"Auto" is the recommended setting.</p>
Serial port B	Auto Disabled 3F8, IRQ4 2F8, IRQ3* 3E8, IRQ4 2E8, IRQ3	<p>Enables or disables onboard serial port B at the specified address.</p> <p>Select "Auto" unless interrupts IRQ4 and/or IRQ3 are allocated as a computer resource.</p> <p>Two devices cannot share the same IRQ. Choosing "Disabled" makes serial port 1 unusable. If selecting "Auto," Setup configures COM1 to address = 3F8h and IRQ = 4 if they are available.</p> <p>"Auto" is the recommended setting.</p>
Parallel port	Auto Disabled 3BC, IRQ 7 378, IRQ 7* 278, IRQ 5	<p>Enables or disables the onboard port at the specified address.</p> <p><b>NOTE:</b> Two devices cannot share the same IRQ. Also, choosing "Disabled" makes the parallel port unusable.</p> <p>"Auto" is the recommended setting.</p>

*continued*

## BIOS Setup Utility

Menu Fields	Settings	Comments
Mode	Compatible mode	Sets the onboard parallel port mode. Standard printer connection.
	Bi-directional mode*	PS/2 compatible mode and able to receive data.
	EPP 1.7	Enhanced parallel port mode.
	EPP 1.9	Selection based on what EPP version the printer supports. Only choose a mode that the parallel port device (such as a printer) supports. Check the parallel port device documentation for this information. If this information cannot be located, use the default setting.
	ECP-DMA1 mode	Extended capabilities port mode.
	ECP-DMA3 mode	
Floppy disk controller	Enabled* Disabled	Enables or disables the onboard diskette controller.
Exchange diskette drives	Disabled* Enabled	Logically exchanges physical diskette drive designations.
Diskette write protection	Disabled* Enabled	Enables or disables the selected diskette drive's write protect option.

*continued*

## BIOS Setup Utility

Menu Fields	Settings	Comments
<b>Advanced Chipset Control</b>		
ECC config	ECC* ECC Disabled	Select the memory configuration for the system.
Enable memory gap	Disabled* Conventional Extended	If enabled, system RAM is turned off to free address space for use with an option card. Either a 128 KB conventional memory gap (starting at 512 KB) or a 1 MB extended memory gap (starting at 15 MB) will be created in system RAM.
AGP Aperture	256 MB* 128 MB 64 MB 32 MB 16 MB 8 MB 4 MB	Select the size of the graphics aperture for the AGP video device.
Onboard VGA auto disable	Yes No	If set to Yes, system will disable on-board VGA if add-in VGA card is installed. Otherwise, the onboard VGA will remain enabled to allow multi-monitor support.
<b>Sound</b>		
Midi Keyboard Support	Enable Disable	Select "Enable" if the workstation uses a MIDI keyboard. Otherwise, select Disable.
<b>Integrated Network Controller</b>		
Remote network wakeup	Enable Disable*	Select "Enable" if you want to use Remote Network Wakeup with this workstation. Otherwise, select Disable.
Client operation	Enable Disable*	Select "Enable" if you want to allow client operation of this workstation. Otherwise, select Disable.

## Security Options

Menu Fields	Settings	Comments
Supervisor password is	Not user selectable (Disabled)*	Indicates whether or not the supervisor's password is enabled or disabled.
User password is	Not user selectable (Disabled)*	Indicates whether or not the user's password is enabled or disabled.
Set user password	Press [Enter]	<p>Allows a user password to be set. This password can be set only if a supervisor password is entered.</p> <p>When the user has entered his or her name but the supervisor is not logged in, only the following information is accessible:</p> <p>Supervisor password is Enabled. User password is Enabled.</p> <p>Set user password [press enter] to enter a user password.</p> <p>Password on boot Enabled/Disabled (which ever is in effect). This option is not allowed to change.</p> <p>Custom sign on banner Enabled/Disabled (which ever is in effect). This option is not allowed to change.</p>
Set supervisor password	Press [Enter]	<p>Allows a supervisor password to be set. The supervisor password must be set if a user password is to be used.</p> <p><b>NOTE:</b> Entering Setup with a supervisor password provides full access to all BIOS Setup utility menus.</p>
Custom Sign-in banner	Press [Enter]	<p>Press [Enter] to enter a custom sign on banner that displays during POST.</p> <p>For example, the user might enter "Welcome to John's Machine." The maximum number of characters is 50.</p>

*continued*



## BIOS Setup Utility

Menu Fields	Settings	Comments
Diskette access	Supervisor* User	<p>Controls who has access to diskette drives.</p> <p>If "Supervisor" is selected, access to the diskette drive is limited to the supervisor, who must enter his or her password. If User is selected, the diskette drive can be accessed by entering either the supervisor or the user password.</p> <p>Whatever setting is chosen, it only becomes functional if both a "Supervisor Password" and a "User Password" have been set (if the User setting is chosen).</p>
Password on boot	Enabled Disabled*	<p>Enables or disables the enter password on boot option.</p> <p>If you enable this option, a user or supervisor password must be entered in order for the boot process to complete. If a user or supervisor password is not entered, the operating system cannot be accessed.</p>

## Power

Menu Fields	Settings	Comments
Power savings	Customized* Maximum Power Savings Maximum Performance Disabled	Enable this field to use any of the power management options. If this field is enabled and the other fields are disabled, only minimal power reduction is affected.
Auto standby timeout	Off* 1 min. 5 min. 10 min. 20 min. 30 min.	<p>After a set period of workstation inactivity, the BIOS places the workstation in a standby state (medium power savings), that is, the monitor and CPU are set to power management. Any mouse or keyboard activity quickly returns the workstation to operation.</p> <p>Alternately, you can choose to disable this option and thereby not use this feature. Power savings must be enabled to use this option.</p>
Auto suspend timeout	Off* 1 hour 1.5 hour 2 hour 3 hour	<p>After a set period of workstation inactivity, the BIOS places the workstation in a suspended state (maximum power savings), that is, the monitor and fan are shut off and the CPU and hard disk are powered down. Any mouse or keyboard activity quickly returns the workstation to operation.</p> <p>If you set a timer for the field, you should also set Power savings to Enabled.</p> <p>Alternately, you can choose to disable this option and thereby not use this feature.</p>

*continued*

## BIOS Setup Utility

Menu Fields	Settings	Comments
Resume on modem ring	Off* On	When On, wakes up the system when an incoming call is detected on the modem.
Resume on time	Off* On	When On, wakes up the system at a specific time, set by the Programmable power-on feature.
Programmable power on	Off* On	Sets the time for system wake up by Resume on Time.

## Boot

Menu Fields	Settings	Comments
Floppy check	Enabled* Disabled	"Enabled" permits verification of FDD type at boot. "Disabled" prevents FDD verification and speeds up the boot process.
Summary screen	Enabled* Disabled	Enabling this option causes the workstation to display configuration parameters (in the form of a summary screen) during boot.
Boot device priority	1. Diskette Drive* 2. Hard Drive* 3. CD-ROM Drive*	The numbers refer to the order in which the devices are addressed for the system files needed to boot the system.  To change the order, use the ↑ and ↓ cursor keys to select the device you want to move. Then use the + and – keys, on the numeric keypad, to move the device to the desired boot order.
Hard Drive	List of available bootable devices, for example: Hard Drive* Bootable Add-In Cards	Positioning of the drives may change depending on whether or not legacy option ROMs are present.  To change the order, use the ↑ and ↓ cursor keys to select the device you want to move. Then use the + and – keys, on the numeric keypad, to move the device to the desired boot order.

## Flash Utility

All DIGITAL Personal Workstations have BIOS software in a read-only, non-volatile memory (ROM) chip. This BIOS initializes hardware and boots the operating system when the workstation is turned on. The BIOS also provides access to other services such as keyboard and disk drives.

The workstation comes equipped with flash memory. This means that you can restore the workstation's BIOS simply by running the flash utility. If necessary, you can also upgrade the workstation's BIOS to future releases by running the flash utility along with any flash BIOS update diskette.

Instructions on how to flash your BIOS, the flash utility itself, and BIOS updates are available from the workstation web page:

**<http://www.workstation.digital.com>**

BIOS Setup Utility

# System Software **3**

---

## Introduction

DIGITAL Personal Workstations come with the Windows NT Workstation operating system and pre-installed system management software, utilities, and on-line information. All system software and device drivers needed for workstation configuration are also supplied on the CDs included with the system documentation in the accessories box.

This chapter describes:

- Configuring system parameters
- The location and description of system software and on-line documentation.
- The operating system software kit
- The System Software CD

## Configuring System Parameters

Although the workstation is ready to operate, it may be necessary to change the video configuration, configure a network, or add hardware. The available software can help with these tasks, as explained in the following sections.

### Configuring Video

Before changing the resolution or resetting your monitor type, check the monitor documentation and make the new selections based on what the monitor can support. Use the Control Panel Display option to configure the video and monitor.

*Refer to the Windows NT Workstation Installation Guide and any related on-line help for configuration information.*

*For models equipped with an AGP graphics card, refer to the on-line AGP documentation provided on the AGP card manufacturer's CD included with the workstation.*

### Configuring Networking

If your computer has onboard network capability, configuration information is available to you on the System Software CD-ROM disc. See the CD-INFO.TXT file on the System Software CD for configuration and installation information.

### Configuring Additional Hardware

Adding hardware requires configuring the workstation's IRQ and DMA settings. Use the ISA Configuration Utility (ICU) diskette to help determine the available resources.

## The ISA Configuration Utility (ICU)

Before installing a new card in the workstation, run the ICU to determine available system resources. The ICU provides a database of configuration information for many ISA cards. If the new card is not in the database, the ICU can still help determine a working configuration for the card. Consult the documentation that came with the ISA card to determine valid configuration values.

See the CD-INFO.TXT file on the DIGITAL System Software CD for information about creating the ICU diskette.

*See the ICU on-line help for complete instructions.*

## DIGITAL Supplied Software



**NOTE:** Not all software is supported in all languages for all countries. If software is not pre-loaded, then DIGITAL does not support using the System Software CD to install an English (or a Non-English) application or utility on non-matching language variations of Microsoft operating systems.

Included with the workstation are software applications, utilities, and on-line documentation. The operating system comes fully installed and ready to run. Some applications are loaded into the hard disk in a compressed format, but not fully installed. Before you can use one of these applications, you must specifically activate it. Still other applications and drivers come only on the supplied System Software CD. (See the section “Digital System Software CD” for more information.)

An easy-to-use HTML-based interface is provided for installation of these applications.

Follow the steps below to install the customer activated options.

1. From the Start menu, click “Programs.”
2. From the Programs list, click “DIGITAL,” then click on “Installable Options.”
3. The Main Menu appears. Click on the application you want to install.
4. Follow the on-screen instructions to completely install the application onto your hard disk drive.



## Applications

The following table provides the location and a description of the workstation's applications. Depending on the specific DIGITAL Personal Workstation, the applications may vary from the tables presented in this guide.

Applications	Location	Description
Alta Vista Personal Search	Select Programs, Digital, then Installable Options.	Alta Vista Personal Search allows you to search all files on the workstation's hard disk drive. This application is an installable option and must be installed onto the hard disk drive before it can be used.
Adobe Acrobat Reader	Select Programs, Digital, then Installable Options.	The Adobe Acrobat Reader software allows you to read and print electronic documents. This application is an installable option and must be installed onto the hard disk drive before it can be used.
AMI Diagnostics	Can be run from the DIGITAL System Software CD.	AMI Diagnostics can help troubleshoot the workstation even if you are unable to access the hard drive.  In addition to being able to run AMI Diagnostics from the System Software CD, diskette images have been provided so you can create a set of diagnostic diskettes. (See the section "Using Diagnostics.")
ClientWORKS	Select Programs, Digital, then Installable Options.	ClientWORKS is DIGITAL's client management software designed to help network administrators lower the total cost of ownership by automating asset management tasks and managing computers remotely.
Desktop Wellness	Select Programs, Digital, then Desktop Wellness.	Desktop Wellness is a tutorial that contains ergonomic information to help you work comfortably. This tutorial can be used to find aspects of your tasks and work environment that can be adjusted to suit your needs.
Zero Administration Kit	System Software CD.	The Zero Administration Kit is a set of tools for managing Windows NT. The Zero Administration Kit greatly reduces the amount of time that end users must spend in such "house keeping" chores.
Video Utilities	Select Control Panel, then Display.	Refresh utilities allow you to set the refresh rate of the display.

## DIGITAL On-Line Documentation

DIGITAL provides an on-line resource library for all available product information. The resource library may include HTML-based help files, electronic reference guides, and Readme files. Electronic reference guides are available in Adobe Portable Document Format (PDF). The Adobe Acrobat Reader is provided on the workstation's hard disk drive as a customer-activated option.



**NOTE:** Translations of the English versions of the PDF files might be located on the System Software CD.

The following table lists the on-line documentation available for the workstation. These files are supplied on the hard disk drive and can also be installed from the DIGITAL System Software CD.

On-line Documentation	Description
README.TXT	README.TXT files help you set up, operate, and configure your computer. DIGITAL recommends that you read this information first.
<i>System Reference</i>	The on-line System Reference guide describes how to operate, upgrade, and configure your computer. You can view and print the guide using the Adobe Acrobat Reader.
<i>Your DIGITAL Personal Workstation</i>	HTML-based on-line help files that describe your computer's features.
CD-INFO.TXT	This text file provides details about what files are on the System Software CD, and how to install these items onto your computer's hard disk drive.

Other on-line documentation files are available, many of which relate to specific applications. Check the application program folder. Also check the applications themselves for the on-line help that is integrated into the applications.

## Operating System Kit

The workstation comes with Windows NT installed and with the Windows NT Workstation kit. The Windows NT Workstation kit consists of :

- The Windows NT Workstation CD
- Setup diskettes
- Software license
- The *Microsoft Windows NT Installation Guide*

## DIGITAL System Software CD

Included with the workstation's accessories kit is the DIGITAL System Software CD. This is a *bootable* CD capable of being used to boot a workstation on which the hard disk drive has failed. This CD does not contain the operating system.

This DIGITAL System Software CD contains the following items:

<b>Item</b>	<b>Description</b>
DIGITAL on-line documentation	User guides, on-line help, and text files that explain how to operate your computer.
Software applications	Software products that will help you to obtain the most benefit from your DIGITAL computer.
Device drivers	Drivers that are needed for proper computer functions.
Troubleshooting utilities	Utilities (such as AMI Diagnostics) that aid in troubleshooting the computer when it's experiencing problems. See "Using Diagnostics" for more information.
Diagnostic diskette images	Images to create AMI Diagnostic diskettes that can then be used in the event that your computer fails to boot.

## ClientWORKS

ClientWORKS, DIGITAL's client management software, contains a powerful set of utilities designed to help you get the most out of your networking environment. Based on the Desktop Management Interface (DMI) industry-standard, ClientWORKS reduces total cost of ownership and makes DIGITAL Personal Workstations more manageable than the competition. Included, at no charge, with all new DIGITAL Personal Workstations, ClientWORKS saves MIS personnel time, reduces travel costs when diagnosing remote computers, and improves accuracy of analysis of clients on the network.

ClientWORKS includes:

- Enhanced 32-bit DMI service layers for Windows NT.
- DIGITAL's enhanced system Management Information Format (MIF) file for industry-standard desktop management.
- Enhanced ClientWORKS browser, offering identification of DMI components, both locally and remotely.
- SNMP agent software, including a MIF-to-MIB converter for powerful remote management in heterogeneous environments.
- MIFMAKER, DIGITAL's unique utility designed to make DMI data available to Microsoft Systems Management Server (SMS).
- Diagnostics for enhanced system troubleshooting.

For installation instructions, refer to the ClientWORKS on-line help and user documentation. A System Administrator's guide is also provided in PDF file format in the ClientWORKS directory.

*For additional information, including last-minute release notes, see the README.TXT file provided with ClientWORKS.*

## Using Diagnostics

Use the following applications to troubleshoot problems on the workstation.

- Windows NT Diagnostics
- AMI Diagnostics

### Windows NT Diagnostics

To troubleshoot the workstation with this software, choose “Administrative” Tools from the Programs menu and then select the Windows NT icon. See the Windows NT documentation for more information about Windows NT diagnostics.

### DOS-based Diagnostics

Diagnostic options include AMI Diagnostics, a DOS-based diagnostic application, on the DIGITAL System Software CD.

#### AMI Diagnostics on CD

Boot the system from the DIGITAL System Software CD in the event of a hard disk drive failure. Then use AMI Diagnostics to examine the computer’s current configuration, locate faulty components, and troubleshoot problems. If the hard disk drive fails to boot or you are unable to access the diagnostic software from Windows NT Workstation, proceed as follows.

1. Insert the DIGITAL System Software CD into the CD-ROM drive and power on the workstation.
2. After the workstation boots, the startup menu appears. Select “Run Diagnostics” and follow the instructions displayed on the monitor.
3. The DOS-based diagnostics program will launch and the workstation can be tested.

## AMI Diagnostics on Diskettes

Diskette images of the AMI Diagnostics are provided on the DIGITAL System Software CD. DIGITAL recommends that these diskettes be created as soon as possible. The AMI Diagnostic diskette images, stored on the System Software CD, consist of the following:

Title	Description
AMI Diagnostic Diskette #1	This diskette contains the base diagnostics and the Install program to install AMI Diagnostics on the hard disk drive. This is a bootable diskette image.
DIGITAL Vendor Extended Test Diskettes	These diskettes contain additional diagnostics for specific features or options. These are bootable diskette images.

*See the applicable README.TXT file on each of the diagnostics diskettes for installation instructions and additional information.*

## Creating the Diagnostic Diskettes

To create AMI Diagnostic diskettes, follow the steps below:

1. Before beginning, have several blank 1.44 MB diskettes available.
2. Insert the System Software CD into the workstation's CD-ROM drive.
3. The System Software CD will autorun. If you are prompted to choose an operating system, select "Windows NT."
4. At the System Software Main Menu, you are be presented with a menu of software applications from which to choose.
5. Click "Diagnostics" and follow the instructions for creating and labeling the diagnostic diskettes.

### Using the Diagnostic Diskettes

To boot from AMI Diagnostics Diskette #1, insert the diskette into the floppy disk drive and power on the workstation. After the program begins, follow the instructions displayed on the monitor.



**NOTE:** If the computer boots from the hard disk drive instead of the diskette drive, run the BIOS Setup utility to change the boot sequence.

*For more information about each of the diskette images and their use, see the README.TXT file which is included on each diagnostic diskette.*

## Restoring Your Software

The following instructions are for a complete restoration of the workstation's software.

1. Back up data and applications.
2. Reformat the hard disk drive if it failed or if you replaced it with a new one.
3. Install the operating system.

*Refer to the supplied Windows NT Workstation documentation for additional information.*

4. Install the necessary device drivers (see "DIGITAL System Software CD Installation Program").

*For additional installation and configuration information, refer to the CD-INFO.TXT file on the DIGITAL System Software CD.*



**NOTE:** Device drivers are subject to change. You can find the latest device drivers using the Internet (See "Latest Product Information and Updates").

5. Install the DIGITAL supplied applications, such as ClientWORKS. These applications are located on the DIGITAL System Software CD (see the section "DIGITAL System Software CD Installation Program").
6. Install your applications.

If you only need to reinstall a device driver or an application, you can do so by following step 4 or 5 as appropriate.

## DIGITAL System Software CD Installation Program

The DIGITAL System Software CD allows you to install the supplied applications and drivers onto the workstation's hard disk drive.

To launch the installation program:

1. Insert the DIGITAL System Software CD into the CD-ROM drive. It should autorun and launch your Internet browser to display your choices.
2. If you are prompted to choose an operating system, select "Windows NT."
3. A screen listing the installable applications and utilities appears. Select the item you want to install and follow the instructions on the screen.

If the DIGITAL System Software CD does not run automatically:

1. Click "Start," then click "Run."
2. Type "D:\SETUP.HTM" in the Open box (where D:\ is your CD-ROM drive).
3. Click OK.
4. The installation program will launch and you can select what items on the System Software CD you want to install.



**NOTE:** If the workstation does not have an installed CD-ROM drive, then access the DIGITAL System Software CD via the network.



# Troubleshooting **4**

---

## Initial Troubleshooting

The following sections provide initial troubleshooting procedures and tables listing specific problems, probable causes, and recommended actions to take if the workstation fails after configuring it or after installing optional hardware or software.

*Refer to the documentation supplied with the additional options if problems are encountered after installation.*

- Keep it simple: troubleshoot only one problem at a time. Also, make only one change at a time. For example, if the IDE hard disk drive fails to boot, do not try all the suggested actions at once. Instead, start with one suggestion such as checking the cables. After securing the cables, try booting the workstation. If it does not work, try another suggestion.
- Look for abnormal workstation, keyboard, and monitor LED indications. For example, make sure the power on LED lights when you turn on the workstation and the drive access indicators light when using either the diskette drive or hard disk drive.
- If there are POST error(s), run the BIOS Setup utility and fix the problem(s) identified by the POST error(s).
- If you installed external devices, make sure all cables are correctly connected to the appropriate devices.
- If you installed devices inside the workstation, make sure nothing was bumped or jarred loose, and that all cable connections are securely in place.
- Make sure all device drivers are installed correctly.

## Troubleshooting

- If the workstation hangs, soft boot the workstation (press the [Ctrl] + [Alt] + [Del] keys). If the workstation fails to boot, turn it off, wait until all disk drives completely spin down, and then turn it back on.
- Pay close attention to any error message that appears on the screen.

If the error message is workstation related, refer to the “Error Messages” section at the end of this chapter.

If the error message is Windows related, refer to any on-line help and the appropriate Windows documentation supplied with the workstation.

- Listen carefully for workstation errors in the form of beeps. Record the number of beeps and their pattern then refer to the “Error Messages” section at the end of this chapter.
- README files come with the workstation’s factory installed software or as printed material. This README information can help you set up, configure, and operate the workstation.
- Run the diagnostics software. Refer to the following section for information on accessing and running the supplied diagnostics program.
- If the workstation will not boot into Windows NT, use the System Software CD or the Emergency Repair Disk (if the user has created one) to gain access to the workstation’s hard disk. Afterwards, troubleshoot the workstation to correct any problems.

## Pass/Fail Criteria

As a Final Acceptance Test, the following tests should be run to meet the Pass/Fail criteria:

1. Successful completion of the POST tests.
2. Successful completion of the following AMI module tests (one pass):

System Board	(All Tests)
Memory	(All Tests)
Video	(All Tests)
Hard Disk	(All Tests except: sequential write/read and sequential write/random read)
Floppy Disk	(All Tests)
Keyboard	(All Tests)
COM Ports	(All Tests)
LPT Ports	(All Tests)
Pointer Device	(All Tests)
3. Successful bootstrap of the workstation installed operating system.

Operating system supported:

  - Windows NT Workstation

Remove any software that was put on the hard disk drive to enable repair of the workstation before shipping.

When completed, clean the outside of the workstation with cleaning solution.

## Diagnostics

The factory installed Windows NT diagnostics software includes an “Administrative Tools” group in the Programs menu. This program group includes a Windows NT icon for launching the diagnostic software. You can use this software to troubleshoot the workstation.

If you are unable to access the diagnostic software from Windows NT Workstation, a bootable AMI Diagnostics CD-ROM disc can be used. Alternatively, bootable diskette images of AMI Diagnostics are provided on the Digital System software CD-ROM disc.

## ClientWORKS and DMI

ClientWORKS is a Desktop Management Interface (DMI) based software application that has been developed by Digital Equipment Corporation.

ClientWORKS for Windows NT Workstation can be used to help you identify the workstation's current hardware configuration. This ClientWORKS feature is useful if you need to determine if you have sufficient memory or a large enough hard disk for the applications you want to run. You can access ClientWORKS data through Simple Networks Management Protocol (SNMP) consoles. Other features include:

- Serial numbers can easily be identified to obtain warranty service.
- The amount and type of workstation memory you have installed can easily be identified using ClientWORKS. This is especially useful if you need to know the workstation's capabilities prior to loading software.
- A system manager or administrator can use ClientWORKS to remotely access workstation configurations that are attached to a network. This feature enables a system manager or administrator to easily maintain an accurate equipment log.

*Refer to the ClientWORKS on-line help for detailed information on installing or using ClientWORKS.*

## Self-Monitoring, Analysis, and Reporting Technology (S.M.A.R.T)

If the workstation's hard disk is S.M.A.R.T aware and the operating system is Windows NT, DIGITAL's S.M.A.R.T Monitor appraises the user how the hard disk is operating.

When Windows NT starts, DIGITAL's S.M.A.R.T Monitor is launched and immediately minimized, placing the icon in the Windows NT task bar. The DIGITAL S.M.A.R.T Monitor then periodically polls the S.M.A.R.T aware devices in the computer. You can review the status of these devices by selecting **Digital S.M.A.R.T Monitor** on the task bar. You can review general information and drive history or modify the setup of the DIGITAL S.M.A.R.T monitor.

If problems are detected in the workstation's devices, you see a dialog box displaying the error message.

For more information about DIGITAL S.M.A.R.T. Monitor, refer to the *DIGITAL Personal Workstation System Reference*, the *DIGITAL Personal Workstation System Software*, or the ClientWORKS documentation.

## Advanced Troubleshooting

DIGITAL has a Customer Replaceable Unit (CRU) process during the warranty period for:

- DIGITAL monitors with screens less than 20 inches
- Mice
- Keyboards
- Speakers
- Other parts as defined by DIGITAL as CRUs

The DIGITAL CRU process provides for overnight shipment of the part directly to the customer site. The Service provider gives the customer instructions for installing the replacement unit and for returning the defective part. Customers are billed for the specified part if they fail to return the part to DIGITAL within ten days of the replacement unit shipment.

In the following troubleshooting tables, “CRU Process” means that when a part is determined to be broken, the Service provider should use the previously described CRU process.



**NOTE:** The following troubleshooting suggestions are not in any specific order. They are merely a list of possible problems and solutions.

## Workstation Troubleshooting

<b>Problem</b>	<b>Possible Cause</b>	<b>Action</b>
System does not shut down as desired when you press the power switch momentarily	You have not held the power switch in for at least four seconds.	To turn of the workstation, hold the power switch in for four seconds.
No response when the workstation is turned on.	Workstation is not plugged in.	Plug in the workstation and then turn it on.
	No power at the wall outlet.	Use another wall outlet.
	Main logic board failure.	Replace the main logic board.
	Main logic board jumpers/switches incorrectly set.	Set all appropriate jumpers/switches (Refer to Chapter 5).
	CPU has failed.	Replace the CPU.
	Power supply has failed.	Replace the power supply.
Power is on, screen is on, but the workstation does not respond.	Voltage select switch is set incorrectly.	Make sure the setting on the back of the workstation matches the country's voltage requirements. Refer to the on-line <i>Quick Setup</i> Guide for more information.
	Keyboard not connected, mouse not connected, or both might be in the wrong port.	Connect the keyboard and/or mouse. If already connected, confirm that each device is in the appropriate port.

*continued*



## Troubleshooting

<b>Problem</b>	<b>Possible Cause</b>	<b>Action</b>
Power is on, but there is no screen display.	Brightness and contrast controls are not correctly set.	Adjust the brightness and contrast controls.
	The monitor-off timer has shut the monitor off.	Press [Shift] to reactivate monitor.
	Monitor is off.	Turn on the monitor.
	Monitor cable is incorrectly installed.	Check all monitor connections.
	Incorrect video drivers installed.	Install the correct video drivers.
	Video controller has failed. Monitor has failed.	Replace the video expansion board. To ensure the problem is a monitor failure, try another monitor if possible. If the new monitor works correctly, follow the CRU process to replace the monitor.

*continued*

## Troubleshooting

<b>Problem</b>	<b>Possible Cause</b>	<b>Action</b>
Workstation operates incorrectly after installing an optional expansion board.	Expansion board installed incorrectly.	Remove the expansion board and reinstall.
	Did not run the ISA Configuration Utility (ICU) to configure a non-Plug and Play expansion board before installation.	Run the ICU to properly configure expansion board and then reboot the workstation. Refer to any supplied ICU and Windows NT Workstation documentation.
	<b>Note:</b> Plug and Play expansion boards are automatically configured.	
Workstation operates incorrectly after installing optional DIMMs.	Expansion board has failed.	Remove expansion board and reboot. If workstation boots without errors, replace expansion board.
	DIMMs installed incorrectly.	Remove DIMMs and reinstall.
	DIMMs have failed.	Replace DIMMs.
	Registered and unbuffered DIMMs have been mixed.	Use only one type of DIMM (registered or unbuffered).

*continued*

## Troubleshooting

<b>Problem</b>	<b>Possible Cause</b>	<b>Action</b>
Workstation fails to retain setup information.	Workstation battery has failed.	Replace workstation battery.
	CMOS Clear switch (SW1-3) set to "Enable."	Set CMOS Clear switch to "Disable."
Workstation displays HIMEM.SYS errors.	Unstable memory at the specified address.	Replace faulty DIMM(s). Use only one type of DIMM (registered or unbuffered).
Workstation displays a System Error F002 message	Faulty hardware.	Run the supplied diagnostic software to identify the faulty hardware. Replace the faulty hardware.

*continued*

## Troubleshooting

<b>Problem</b>	<b>Possible Cause</b>	<b>Action</b>
"Couldn't Find NTLDR"	NTLDR file is missing from the root directory of the hard disk drive.	<p>Copy the NTLDR file to the hard disk drive's root directory.</p> <p>If using the supplied Windows NT Workstation CD-ROM disc, make the CD-ROM the current drive and then type:</p> <pre>copy\i386\ntldr c:\</pre> <p>at the command line prompt.</p> <p>If using the supplied Windows NT Workstation Setup disks, insert Setup Disk #2 into the diskette drive and then type:</p> <pre>expand ntldr.\$ C:\ntldr</pre> <p>at the command line prompt.</p>
"Error 000001E"	The hard disk drive might have corrupted system files.	<p>Run chkdsk on the hard disk to correct any corrupted files. Also, make sure that the hardware is on the <i>Microsoft Windows NT Hardware Compatibility List</i>.</p>

*continued*

## Troubleshooting

<b>Problem</b>	<b>Possible Cause</b>	<b>Action</b>
"Error 0x00000069 or 0x00000067"	Windows NT Workstation unable to communicate with the workstation's hard disk drive controller.	<p>Using the BIOS Setup utility, slow down the DMA transfer rate of the controller.</p> <p>Make sure both ends of the SCSI bus are terminated and all SCSI devices are not terminated.</p> <p>Make sure there are no IRQ or memory address conflicts.</p> <p>Make sure NTDETECT.COM is in the root directory of the boot drive partition.</p> <p>Make sure there are no missing Windows NT Workstation system files.</p> <p>If the problem still exists, replace the main logic board.</p>
"NMI Hardware Error"	Faulty hardware.	<p>Make sure all DIMMs, processor, VRM, video memory, and expansion board connectors are clean and properly seated in their respective sockets.</p> <p>Run the supplied diagnostic software to identify the faulty hardware. Replace any faulty hardware.</p>
Services or subsystems do not start properly	Improper configuration, files missing or files not installed.	<p>Use the <i>Services</i> or <i>Devices</i> icons in the <i>Control Panel</i> menu to check for status. Also, check the system log in the <i>Event Viewer</i> for entries relating to the problem.</p> <p>If the problem still exists, reinstall the operating system.</p>

*continued*

## Troubleshooting

<b>Problem</b>	<b>Possible Cause</b>	<b>Action</b>
Workstation does not boot from an IDE hard disk drive.	IDE drive type incorrect.	Run the BIOS Setup utility to identify the correct drive type. See drive type label on drive or consult drive documentation.
	Loose cables. Onboard IDE interface disabled. Hard disk boot sector is missing.	Secure all cable connections. Run the BIOS Setup utility and set the Local Bus IDE Adapter to "Enabled." Restore the boot sector. (See your Operating System documentation for the instructions about how to do this.) Re-partition and reformat the hard disk. <b>Caution:</b> This procedure erases what is currently on the hard disk drive. You might want to try repairing the hard disk drive using a disk drive repair utility. Disk drive repair utilities can be purchased from the local software supplier. If you do repartition and reformat the hard disk drive, proceed as follows for Windows NT Workstation. Boot from a DOS diskette then enter the following commands: <pre>a : cd \Dos fdisk</pre> Follow the instructions on the monitor screen to create a new hard disk boot sector.
	There might be a boot sector virus.	Run anti-virus software.

*continued*

## Troubleshooting

<b>Problem</b>	<b>Possible Cause</b>	<b>Action</b>
Workstation does not boot from an IDE hard disk drive.	IDE hard disk is connected to the wrong IDE connector.	Connect the boot disk to the inner IDE connector on the main logic board.
	Operating system software is not installed on the IDE hard disk drive.	Install the appropriate operating system.
	IDE hard disk drive is not correctly formatted or the requested partition does not exist.	Format the IDE hard disk drive or partition the IDE hard disk drive using the supplied operating system software.
	There is no software on the requested partition.	Install software on the requested partition.
	IDE hard disk drive jumpers incorrectly set.	Refer to the supplied IDE hard disk drive kit installation instructions.
	IDE hard disk drive has failed.	Replace the IDE hard disk drive.
	IDE hard disk drive ribbon cable has failed.	Replace the ribbon cable.
	IDE controller has failed.	Replace the main logic board.

*continued*

## Troubleshooting

<b>Problem</b>	<b>Possible Cause</b>	<b>Action</b>
Workstation does not recognize an internal or external SCSI device.	SCSI device jumpers incorrectly set.	Refer to the supplied SCSI device kit installation instructions.
	SCSI ID conflicts.	Refer to the supplied SCSI device kit installation instructions on setting SCSI IDs.
	Terminating resistors not removed from the SCSI device.	Remove terminating resistors. Refer to the supplied kit installation instructions.
	SCSI option not enabled in BIOS Setup utility.	Run the BIOS Setup utility and enable SCSI option.
	SCSI cable not terminated.	Terminate each end of the SCSI cable.
	SCSI device not plugged in.	Check power and SCSI cables.
	Loose cable connectors.	Secure all cable connections.

*continued*



## Troubleshooting

Problem	Possible Cause	Action
Workstation does not recognize an internal or external SCSI device.	Hard disk boot sector is missing.	<p>Restore the boot section. (See your Operating System documentation for the instructions about how to do this.)</p> <p>Reformat the hard disk.</p> <p><b>Caution:</b> This procedure erases what is currently on the hard disk drive.</p> <p>You might want to try repairing the hard disk drive using a disk drive repair utility. Disk drive repair utilities can be purchased from the local software supplier.</p> <p>If you do reformat the hard disk, proceed as follows for Windows NT Workstation:</p> <p>Boot from a DOS diskette then enter the following commands:</p> <pre>a : cd \Dos fdisk</pre> <p>Follow the instructions on the monitor screen to create a new hard disk boot sector.</p>
	There might be a boot sector virus.	Run anti-virus software.
	Loose cable connectors.	Secure all cable connections.
	SCSI adapter has failed.	Replace the SCSI adapter.
	SCSI ribbon cable has failed.	Replace the ribbon cable.
	SCSI device has failed.	Replace the SCSI device.

*continued*

## Troubleshooting

<b>Problem</b>	<b>Possible Cause</b>	<b>Action</b>
Workstation does not boot from an internal SCSI hard disk drive.	Workstation not configured for SCSI hard disk drive operation.	Run the BIOS Setup utility and set the IDE controller option to "Disabled." This disables the onboard IDE interface. <b>Note:</b> If you have both IDE and SCSI hard disk drives installed, the workstation uses the IDE hard disk drive as the boot device.
	Operating system software is not installed on the SCSI hard disk drive.	Install the appropriate operating system.
	Requested partition does not exist.	Partition the SCSI hard disk drive and then reload the operating software.
	SCSI adapter has failed.	Replace the SCSI adapter.
	SCSI ribbon cable has failed.	Replace the ribbon cable.
	SCSI hard disk drive has failed.	Replace the SCSI hard disk drive.

*continued*

## Troubleshooting

<b>Problem</b>	<b>Possible Cause</b>	<b>Action</b>
Workstation does not boot from a target diskette drive.	Onboard diskette controller disabled.	Run the BIOS Setup utility and set the diskette controller option to "Enabled."
	Diskette drive not enabled.	Run the BIOS Setup utility to enable the diskette drive
	BIOS Setup diskette write option enabled.	Enter the user password. If a supervisor password is required, see the system supervisor or system manager.
	Incorrect diskette drive type.	Run the BIOS Setup utility and select the correct drive type.
	Diskette boot option disabled.	Run the BIOS Setup utility and set the proper boot sequence.
	Incorrect boot order.	Use a bootable diskette.
	Diskette might not be bootable.	Use a bootable diskette.
	Diskette does not contain start-up files.	Insert a diskette with the correct start-up files.
	Diskette drive is empty.	Insert a diskette that contains an operating system.
	Diskette is worn or damaged.	Try another diskette.
	Loose cable connectors.	Secure all cable connections.
	Diskette access requires a supervisor password.	See the supervisor or system manager.
	Diskette access requires a user password.	Enter the user password.

*continued*

## Troubleshooting

<b>Problem</b>	<b>Possible Cause</b>	<b>Action</b>
No response to keyboard commands.	Keyboard is password protected.	Enter the keyboard password.
	Keyboard is not connected.	Power down the workstation and connect the keyboard.
	Keyboard is connected to the mouse port.	Power down the workstation and connect the keyboard to the keyboard port.
	Workstation operation halted.	Reboot workstation.
	Keyboard has failed.	To ensure the problem is a keyboard failure, try another keyboard if possible. If the new keyboard works correctly, follow the CRU process to replace the keyboard.
	Keyboard controller has failed.	Replace the main logic board.

*continued*

## Troubleshooting

<b>Problem</b>	<b>Possible Cause</b>	<b>Action</b>
Keyboard keys type incorrectly.	Incorrect language selected.	Select the correct language.
	Keyboard has failed.	To ensure the problem is a keyboard failure, try another keyboard if possible. If the new keyboard works correctly, follow the CRU process to replace the keyboard.
No response to mouse activity.	Mouse is not connected.	Power down the workstation and connect the mouse.
	Mouse is connected to the keyboard port.	Power down the workstation and connect the mouse to the mouse port.
	Workstation operation halted.	Reboot workstation.
	Mouse driver not installed.	Install the appropriate mouse driver. Refer to the on-line System Software manual.
	Onboard mouse controller disabled.	Run the BIOS Setup utility and set the mouse port option to "Enable."
	Mouse has failed.	To ensure the problem is a mouse failure, try another mouse if possible. If the new mouse works correctly, follow the CRU process to replace the mouse.
	Mouse controller has failed.	Replace the main logic board.
Mouse sticks.	Dirty mouse ball.	Remove mouse ball and clean it.

## Disk Drive Troubleshooting

<b>Problem</b>	<b>Possible Cause</b>	<b>Action</b>
IDE/SCSI hard disk drive cannot read or write information.	Incorrect disk drive jumper settings.	Refer to the supplied kit installation instructions.
	Loose or incorrectly installed cables.	Make sure all cables are correctly installed.
	IDE/SCSI hard disk drive is not correctly formatted or partitioned.	Format and partition as required using the supplied operating system.
	IDE drive type incorrect.	Run the BIOS Setup utility to identify the correct drive type.
	Onboard IDE interface disabled.	Run the BIOS Setup utility and set the Local Bus IDE Adapter to "Both."
	IDE/SCSI hard disk drive has failed.	Replace the hard disk drive.
	IDE/SCSI controller has failed.	Replace the main logic board.
	IDE/SCSI ribbon cable has failed.	Replace the ribbon cable.

*continued*

## Troubleshooting

<b>Problem</b>	<b>Possible Cause</b>	<b>Action</b>
Target diskette drive cannot read or write information.	Diskette is not formatted.	Format the diskette.
	Diskette is worn or damaged.	Try another diskette.
	Diskette is write-protected.	Slide the write-protect switch so the hole is not visible (3½-inch diskette) or uncover the write-protect notch (5¼-inch diskette).
	Diskette drive is empty.	Insert a diskette.
	Onboard diskette controller disabled.	Run the BIOS Setup utility and set the diskette controller option to "Enabled".
	Diskette write protection is enabled.	Run the BIOS Setup utility and set the diskette write protection to "Disabled."
	Loose cable connectors.	Secure all cable connections.
	Diskette drive has failed.	Replace the diskette drive.
	Diskette drive controller has failed.	Replace the main logic board.
	Diskette drive ribbon cable has failed.	Replace the ribbon cable.
Target diskette does not format diskettes.	Diskette access requires supervisor password.	Reboot workstation and enter the supervisor password. Afterwards, run BIOS Setup utility and set "Diskette Access" option to "User."
	Diskette write protection is enabled.	Run the BIOS Setup utility and set the diskette write protection to "Disabled."
	Diskette drive has failed.	Replace the diskette drive.

## Troubleshooting

### Monitor Troubleshooting

<b>Problem</b>	<b>Possible Cause</b>	<b>Action</b>
Monitor power indicator is not on.	Monitor is turned off.	Turn on the monitor.
	Power cord is not connected.	Connect the power cord to the workstation.
	No power at wall outlet.	Use another outlet.
	The monitor-off timer shut off the monitor.	Press [Shift] to reactivate monitor.
	Monitor has failed.	To ensure the problem is a monitor failure, try another monitor if possible. If the new monitor works correctly, follow the CRU process to replace the monitor.
	Video controller has failed.	Replace the video expansion board or, if the monitor is plugged into the on-board video, replace the main logic board.
	Power indicator is defective.	Follow the CRU Process to replace the monitor.
No screen display.	Configuration error.	Run the BIOS Setup utility to configure the workstation for correct video operation.
	Monitor brightness and contrast controls are incorrectly set.	Adjust the monitor brightness and contrast controls.
	The monitor-off timer shut off the monitor.	Press [Shift] to reactivate monitor.
	Wrong Windows driver loaded.	Load the correct video driver.

*continued*



## Troubleshooting

<b>Problem</b>	<b>Possible Cause</b>	<b>Action</b>
No monitor display while loading Windows video drivers.	Monitor type incorrectly set.	Set the correct monitor type using the appropriate utility.
Distorted, rolling, or flickering screen display, or wrong/uneven color.	Monitor incorrectly adjusted.	Adjust accordingly.
	Monitor signal cable incorrectly installed.	Straighten any bent connector pins and then reconnect.
Color monitor displaying monochrome.	Workstation was turned on before the monitor was turned on.	Turn off the workstation, turn on the monitor, then turn the workstation back on.
Monitor fails to switch to high-resolution mode.	Appropriate high-resolution video drivers are not installed or incorrectly installed.	Correctly install all appropriate high-resolution video drivers. Refer to the documentation supplied with the monitor.
Monitor display disappears.	Screen display sized incorrectly.	Correctly size screen display.
High-end graphics not functioning properly.	Graphics card not in the primary slot.	Verify that the graphics card is in the primary slot, preferably the second one.

## Audio Troubleshooting

<b>Problem</b>	<b>Possible Cause</b>	<b>Action</b>
Audio does not work.	Sound, MIDI, mixer drivers not installed.	Check the error messages for the necessary drivers. In the Windows Control Panel, select "Multimedia" to install the necessary device drivers.
	Address contention. Two or more devices might be trying to access the same address.	Check IRQ, I/O address, and DMA settings in Windows NT Workstation or BIOS Setup. Change settings as required.
	Cables loose or not properly connected.	Make sure speaker and mic plugs are in correct jacks. Reconnect cables.
	Onboard audio controller disabled.	Run the BIOS Setup utility and set the Integrated Audio to "Enabled."
	Bad audio chip or sound card.	Replace the main logic board or sound card.
	Main logic board has failed.	Replace the main logic board.

*continued*

## Troubleshooting

<b>Problem</b>	<b>Possible Cause</b>	<b>Action</b>
External speakers do not work.	Speakers not connected or improperly connected.	Properly connect the speakers. Refer to the <i>System Reference</i> manual for more information.
	Speaker batteries or ac adapter have failed.	Replace speaker batteries or ac adapter. Refer to the documentation that came with the speakers.
	Speakers have failed.	To ensure the problem is an external speaker failure, try another set of speakers, if possible. If the new speakers work correctly, follow the CRU process to replace the speakers.
Microphone does not work.	Microphone not connected or improperly connected.	Properly connect the microphone. Refer to the <i>System Reference</i> manual for more information.
	Microphone has failed.	To ensure the problem is a microphone failure, if possible, try another microphone. If the new microphone fails to operate, follow the CRU Process to replace the microphone.
Headset does not work	Headset not connected or improperly connected.	Properly connect the headset. Refer to the <i>System Reference</i> for more information.
	Headset has failed.	To insure that the problem is a headset failure, try another headset, if possible. If the new headset works correctly, follow the CRU Process to replace the headset.

## Troubleshooting

### CD-ROM Troubleshooting

<b>Problem</b>	<b>Possible Cause</b>	<b>Action</b>
Cannot access the CD-ROM drive. Error message reading drive x.	Device drivers not installed.	Install correct device drivers.
	No disk in the CD-ROM drive.	Insert a disk.
	CD-ROM drive tray is open.	Close the tray.
	Onboard IDE interface disabled (if IDE CD-ROM)	Run the BIOS Setup utility and set the Local Bus IDE Adapter to "Enabled."
	CD-ROM has failed.	Replace the CD-ROM.
Power is on but CD-ROM drive indicator shows no activity.	Cables have failed.	Replace defective cables.
	No CD-ROM disc or CD-ROM drive tray is open.	Insert a disk and close the tray.
	Cables are loose or not connected.	Make sure cables are correctly connected.
	CD-ROM has failed.	Replace the CD-ROM.
CD-ROM disc is spinning but CD-ROM drive is idle.	Cables have failed.	Replace defective cables.
	Application software not running.	Run application software.

## Network Interface Troubleshooting

Problem	Possible Cause	Action
Power is on, LAN address is installed on workstation; system hangs.	Incorrect software installed or software installed incorrectly.	Contact system administrator or network coordinator.
Workstation is on, no keyboard response.	Incorrect IRQ.	Check BIOS setup and Windows NT Workstation settings.
Network doesn't start.	Network cable not connected or is loose.	Connect cable.
	Conflict exists with another device adapter; incorrect IRQ setting.	Check BIOS setup or Windows NT Workstation settings.
	Network cable has failed.	Contact the system administrator or network coordinator.
	Onboard network controller disabled.	Run the BIOS Setup utility and set Integrated Ethernet to "Enabled."
	Onboard network controller has failed.	Replace the main logic board.

## Error Messages

This section lists workstation messages that might be seen or heard when turning on power. The workstation messages are grouped as follows:

- POST and boot workstation messages
- POST execution messages
- Beep codes

## POST Messages

The POST displays messages to alert the user to errors in hardware, software, and firmware or to provide operating information about the workstation.

Each time the POST displays a message on the screen, the workstation's speaker beeps twice. If an error occurs before the monitor is initialized, specific beep codes sound to alert the user to a problem. The following table lists a general grouping of workstation messages. In addition, each message is accompanied by text describing the message and in most cases, a recommended solution to the problem.



**NOTE:** Italics indicate variable parts of a message such as memory addresses, hexadecimal values, and so on. These messages can differ at each occurrence.

## POST and Boot Messages

Message	Description/Solution
Asynchronous Synchronous Burst Synchronous Pipeline Burst Passed	Where <i>nnnn</i> is the amount of workstation cache (in kilobytes) that tested successfully.
Diskette drive A error	Run the BIOS Setup utility. Check all connections. If the problem persists, replace the diskette drive.
Diskette drive B error	
Entering SETUP	BIOS Setup utility runs.
Extended RAM Failed at offset: <i>nnnn</i>	Extended memory failed or configured incorrectly.  Make sure DIMMs are installed correctly (Refer to on-line <i>System Reference</i> manual). If the problem persists, replace any faulty DIMMs.  Run the BIOS Setup utility and restore all settings to original values.
Extended RAM Passed	Where <i>nnnn</i> is the amount of extended memory (in kilobytes) that tested successfully.
Failing Bits: <i>nnnn</i>	<i>nnnn</i> is a map of the bits at the RAM address which failed the memory test.  Run the BIOS Setup utility and restore all to original values.  If the problem persists, replace any faulty DIMMs.
Fixed Disk 0 Failure	Run the BIOS Setup utility. Check all connections. If the problem persists, replace the hard disk drive.
Fixed Disk 1 Failure	
	Fixed disk controller failure

*continued*

## Troubleshooting

Message	Description/Solution
Incorrect Drive A type - run SETUP	Diskette drive A and/or B not correctly identified in the BIOS Setup utility.
Incorrect Drive B type - run SETUP	Run the BIOS Setup utility and properly identify diskette drive A and/or B.
Invalid NVRAM media type	NVRAM access failed. Run the BIOS Setup utility and restore all settings to original values. If the problem persists, replace the main logic board.
Keyboard controller error	Check the keyboard connection. If the connection is secure, the keyboard or keyboard controller might have failed. If the problem persists, replace the main logic board or keyboard.
Keyboard error	
Keyboard locked - Unlock key switch	
Monitor type does not match CMOS - Run SETUP	Run the BIOS Setup utility and set the correct monitor type.
Operating system not found	The operating system cannot be found on drive A or drive C. Run the BIOS Setup utility and correctly identify drive A or drive C. Correctly install the operating system. Refer to the supplied operating system documentation.
Press <F1> to resume, <F2> to Setup.	This message appears after any recoverable error message. Press [F1] to ignore the error and continue or [F2] to enter the BIOS Setup utility to make any necessary changes.
Real time clock error	Battery failed BIOS test. Replace battery and then run the BIOS Setup utility to restore previous configuration information.

*continued*



Message	Description/Solution
Shadow RAM Failed at offset: <i>nnnn</i>	Shadow RAM failed. Run the BIOS Setup utility and disable failed shadow memory region.
<i>nnnn</i> Shadow RAM passed	Where <i>nnnn</i> is the amount of shadow RAM (in kilobytes) that tested successfully.
RTC is dead - Replace and run SETUP	Replace the RTC and then run the BIOS Setup utility to restore previous configuration information.
System BIOS shadowed	This indicates that the workstation's BIOS was successfully copied to shadow RAM.
System cache error - Cache disabled	RAM cache failed. Run the BIOS Setup utility and restore all settings to original values. If the problem persists, replace faulty processor.
System CMOS checksum bad - run SETUP	Run the BIOS Setup utility to restore original values. If the problem persists, replace the main logic board.
System RAM failed at offset: <i>nnnn</i>	System RAM failed. Run the BIOS Setup utility and restore all settings to original values. If the problem persists, replace any faulty DIMMs.
<i>nnnn</i> System RAM passed	Where <i>nnnn</i> is the amount of system RAM (in kilobytes) that tested successfully.
System timer error	The workstation's timer test failed. Run the BIOS Setup utility and restore all settings to original values. If the problem persists, replace the main logic board.
UMB upper limit segment address: <i>nnnn</i>	Displays the address of the upper limit of UMB. This indicates the released segments of the BIOS that can be reclaimed by a virtual memory manager.
Video BIOS shadowed	This indicates that the workstation's video BIOS was successfully copied to shadow RAM.

## POST Error Codes and Beep Codes

When POST finds an error and cannot display a message, it places a value in I/O port 80h and, in many cases, causes the workstation's speaker emits a series of beeps to indicate the error. For example if the video configuration fails or if an external ROM module fails a checksum test, then the workstation beeps four times, one long beep, two sets of two short beeps, and one set of three short beeps.

The following table lists other errors and their associated beep codes. Each code represents the number of short beeps that are grouped together. Fatal errors (errors that lock up the workstation) are generally the result of a failed main logic board or some other add-on component (DIMM, BIOS, workstation battery, etc.).

Port 80h	Beeps	POST Routine Description
08		Initial Chipset registers' POST value
0A		Initial CPU registers
0B		Enable CPU cache
0C		Initial Cache registers' POST value
0E		Initial I/O Chip registers' POST value
0F		Enable the local bus IDE
10		Initial Power Management
14		Verify 8742 is responding
16	1-2-2-3	BIOS ROM checksum
18		Initial all three of the 8254 timers
1A		Initial DMA setting
1C		Initial 8259
20	1-3-1-1	Test DRAM refresh
22	1-3-1-3	Test 8742 Keyboard Controller
28		RAM Autosize
29	1-3-3-2	Initial Post Memory
2C	1-3-4-1	Test 512K base address lines
2E		Test 512K base memory
34	1-4-2-1	Test CMOS

*continued*

## Troubleshooting

Port 80h	Beeps	POST Routine Description
38		Shadow the system BIOS
3A		Cache Autosize
46		Check ROM copyright notice
47		Initial PCI Option ROM Manager
49		Initial PCI
4A		Initial all video adapters
4C		Shadow video BIOS ROM
52		Keyboard Test
58	2-2-3-1	Test for unexpected interrupts
5C		Test RAM between 512K and 640K
60		Extended Memory Test
62		Extended Address lines Test
68		Cache Configure
74		RTC Test
76		Keyboard Test
7E		Coprocessor initialization test
82		Test and identify RS232 ports
83		Configure Fisk Disk Controller
8B		Mouse Test
8C		Floppy Test
90		FDisk Test
93		Build the MPTABLE for MP boards
94	3-2-2-1	Disable A20 address line
95		CD Test
9C		Setup Power Management
9D		Initial Security Engine
9E		Enable hardware interrupts
A0		Verify that the system clock

*continued*

## Troubleshooting

<b>Port 80h</b>	<b>Beeps</b>	<b>POST Routine Description</b>
AC		Enter SETUP
B6		Check Password
C0		Try to boot with INT 19

# Parts Replacement **5**

---

## Introduction

The following sections list the Illustrated Parts Breakdown (IPB) part numbers and related replacement procedures.

## Parts Replacement

### DIGITAL Personal Workstation IPB List

Figure Legend	Spare Part Number	Exchangeable Part Number	Description
1	54-25444-01		Main logic board, with SCSI
2	PCMA1-AB		32MB SDRAM DIMM 4 M x 72 unbuffered
	PCMA1-BB		64MB SDRAM DIMM 8 M x 72 unbuffered
	PCMA1-CB		128MB DIMM
	PCMA1-DC		256MB DIMM registered
3	30-50117-01		MOD, CPU card
	70-32729-04		CPU assy, 350 Pentium II, 512K, ECC, W
	70-32729-05		CPU assy, 400 Pentium II, 512K, ECC, W
4	20-50190-01		MOD, VRM, 8.1 DC-DC converter (slim)
5	30-47661-05		Power supply, 300 W
6	54-25432-01		MOD, rear panel, BNC LAN & MIDI
7	30-46506-11		SCSI Controller
8	54-25326-01		Audio card
	54-25326-02		
9	74-50747-01		Option filler plate
10	12-41474-05		Battery, 3 VDC lithium, CR2032

(1) N/I = Not Illustrated

Parts Replacement

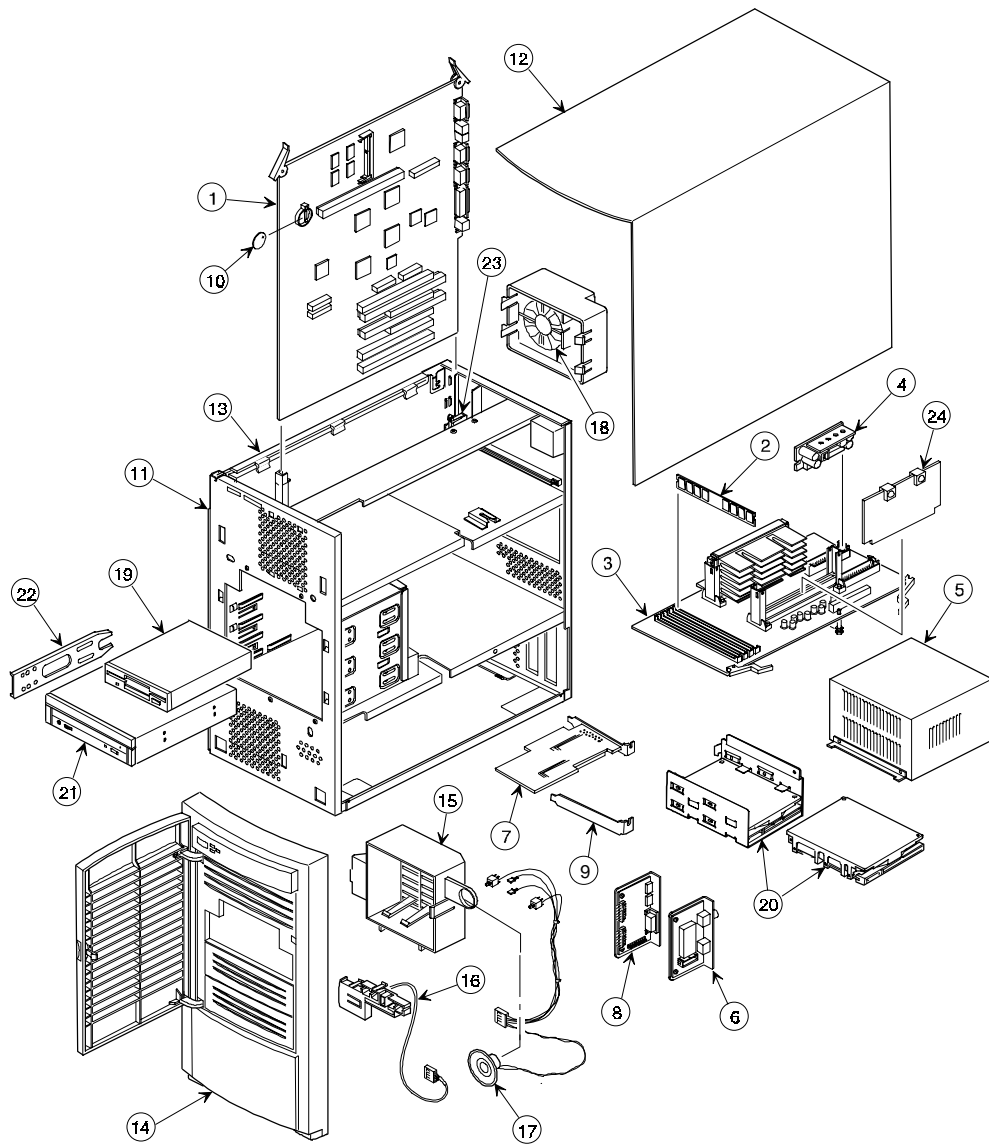

DIGITAL PERSONAL WORKSTATION

DEC01585

Figure 5-1. DIGITAL Personal Workstation

## Parts Replacement

### Enclosure

Figure Legend	Orderable Spare Part	Exchangeable Spare Part	Description
11	70-32678-07		Enclosure
12	70-33124-03		Cover, L-shape
13	74-33125-03		Side panel, left
14	70-33006-01		Bezel, with filler panels
15	74-50755-01		Guide, option cards
16	74-50863-01		Control panel
17	17-04372-04		Speaker/LED, switch wire harness assembly
18	74-51236-01		Fan mount, universal
N/I <sup>(1)</sup>	90-17008-02		Screw, captive 6-32
N/I <sup>(1)</sup>	74-51171-01		3.5" FDD shield, blank
N/I <sup>(1)</sup>	74-50914-01		Bezel, 3.5" FDD blank
N/I <sup>(1)</sup>	74-51239-01		Filler, vent cover, bottom front
N/I <sup>(1)</sup>	74-51361-01		Vent cover, top front
N/I <sup>(1)</sup>	74-51362-01		Vent cover, top rear
N/I <sup>(1)</sup>	74-48816-01		Medallion, front panel (DEC logo)
N/I <sup>(1)</sup>	74-50804-01		Rubber feet
N/I <sup>(1)</sup>	74-50911-01		Bracket, I/O expansion
N/I <sup>(1)</sup>	54-24526-01		MOD, front panel audio board and wire harness

<sup>(1)</sup> N/I = Not Illustrated



## Storage Devices

Figure Legend	Orderable Spare Part	Exchangeable Spare Part	Description
19	PCXRJ-AD		1.44MB floppy disk drive frost white flat bezel
20	RZ2CC-KA RZICC-BA		4.3GB, 1", 7200 rpm Ultra SCSI Hard Disk, S 4.3GB, 1", 7200 rpm Ultra SCSI Hard Disk, S (acceptable substitute)
	PCXRA-AT PCXRA-AU RZ1BC-BA RZ1DB-BA		4.3GB UMDA IDE Hard Disk, Quantum 6.4GB UDMA IDE HDD 2.1GB UW SCSI HDD 9.1GB UW SCSI HDD
21	PCXRN-AQ PCXRN-AN		32x max IDE CD-ROM, TEAC 32x max IDE CD-ROM, Toshiba XM (Acceptable substitute)
22	79-49365-01		Holder, drive rail (comes with enclosure)
N/I <sup>(1)</sup>	90-11334-01 90-08020-01		Screw, machine 6-32 pan .187 x XRCS (HDD) Screw, machine 6-32 pan .187 x XRCS (HDD) (acceptable substitute)
N/I <sup>(1)</sup>	90-40217-01 90-10961-01		Screw, machine M3 pan 5 mm x XRCS CSZ (FDD) Screw, machine M3 pan 5 mm x XRCS CSZ (FDD) (acceptable substitute)
N/I <sup>(1)</sup>	74-46480-01 74-44337-02		Expansion bracket 5.25" to 3.5" Expansion bracket 5.25" to 3.5" (acceptable substitute)

<sup>(1)</sup> N/I = Not Illustrated

## Parts Replacement

### SCSI Adapter Cards

Figure Legend	Orderable Spare Part	Exchangeable Spare Part	Description
N/I <sup>(1)</sup>	30-46729-03		Adaptec 2940UW PCI SCSI adapter

<sup>(1)</sup> N/I = Not Illustrated

### Cables and Terminator

Orderable Spare Part	Exchangeable Spare Part	Description
17-03461-17		Cable assy, 40 cond., flat 28AWG, 415 mm
17-04331-03		Cable assy, flat, 16P IDC to 16P I
17-04550-03		Cable assy, flat, 68 cond., 30AWG, male
17-04696-01		Cable assy, flat, 34 pos, 460mm
70-31909-04		Cable assy, micro switch, 7.0 inches
17-04373-03		Wire harness assy, shield, UL2547
17-04372-01		Cable, control panel
17-04405-02		Cable, 16 pos, LAN 10
17-04278-02		Cable, audio, IDE CD-ROM
17-04405-07		AUI/BNC LAN cable
54-25302-02		MOD, CPU termination card
12-45538-02		68-pin internal SCSI terminator

## Miscellaneous

Orderable Spare Part	Exchangeable Spare Part	Description
30-43276-01		Headset
30-43275-01		Microphone
30-46117-02		Mouse, 3-button, frost white, single pack
DE500-BA		10/100Base Ethernet adapter
12-21778-01 or 90-09538-02		Bumper for MLB
12-44211-01		Fan, tube axial 3.5" DC brushless
12-45246-04		Fan, tube axial, 80 mm DC brushless
70-33077-01		Key-lock assy
74-51992-01		MLB base pan bracket

## Service Procedures

The following sections provide detailed service instructions for DIGITAL Personal Workstations.



**CAUTION:** Static electricity collects on non-conductors such as paper, cloth, or plastic. A static discharge can be damaging even though you often cannot see or feel it. To prevent damage to circuit boards and/or components:

- Before touching any circuit board or component, touch the metal frame of the workstation to discharge any static electricity.
- Keep circuit boards and components away from non-conductors.

## Recommended Tools

Have the following tools available:

- Multimeter (4½-inch digit)
- Phillips screwdriver
- Anti-static wrist strap (recommended, but not required)

## Other Materials Needed

Cleaning agent should be an all purpose cleaner that is used in-house.

## Special Tools Required

None.

## Remedial Diagnostic Test Software

Supplier information:

AMI Diagnostics  
6145-F Northbelt Parkway  
Norcross, GA 30071, U.S.A.  
Voice: 1-770-246-8600  
FAX: 1-770-246-8791  
Support: 1-770-246-8645  
Internet: <http://www.megatrends.com>

## Virus Software Information

F-PROT, Virus Detection and Cleanup Software, latest version.

Supplier information:

North America, South America, Australia and New Zealand  
Command Software Systems Inc.  
Tel: +1-407-575 3200  
FAX: 1-407-575-3026

## BIOS and Driver Information

For access directly to the software library, use the address:

<http://www.workstation.digital.com>

See the section "Latest Product Information and Updates" for a description of how to access the software library.

## Disconnecting External Devices and Power

1. Turn off power to all external devices connected to the workstation.
2. Turn the workstation off.
3. Disconnect power from the wall outlet.
4. Disconnect the power cord and monitor cord.

## Removing the Workstation's Outside Cover

1. Turn off power to all external devices connected to the workstation.
2. Turn the workstation off.
3. Unplug the workstation and monitor power cord from the wall outlet.
4. For workstation's without a chassis lock, go to step 4a. For workstations with a chassis lock, go to step 4b.
  - a. Release the outside cover by loosening the rear-panel thumbscrews.
  - b. Unlock the outside cover by inserting the key and turning it counter clockwise. Loosen the other two rear-panel thumbscrews.
5. Slide the outside cover backwards and then carefully lift it away from the chassis.



**SHOCK OR STATIC SENSITIVE:** Static electricity collects on non-conductors such as paper, cloth, or plastic. A static discharge can be damaging even though you often cannot see or feel it. To prevent damage to circuit boards and/or components:

- Before touching any circuit board or component, touch the metal frame of the workstation to discharge any static electricity.
- Keep circuit boards and components away from non-conductors.

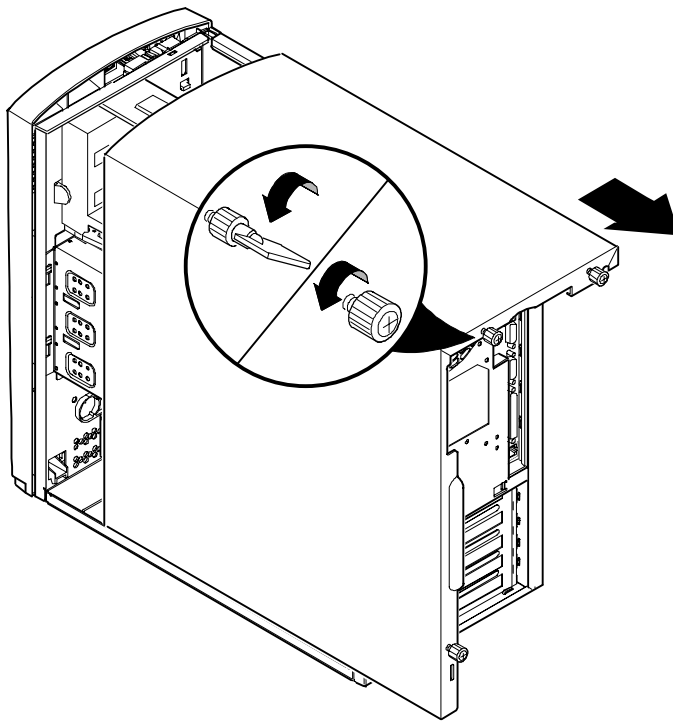

DEC01300-2

**Figure 5-2. Removing the Outside Cover**

## Workstation Components

The following sections identify the DIGITAL Personal Workstation components including: main logic components, main logic board connectors (rear panel), expansion slots, main logic board jumper locations, and memory configurations.

### Main Logic Board Components

Figure Legend	Component
A	3 V dc lithium battery
B	Video memory
C	Permedia 2 graphics/video accelerator
D	Main logic board feature switch
E	SCSI controller
F	Workstation flash BIOS
G	Super I/O controller
H	DIGITAL 21143 PCI Ethernet controller
I	Wave table
J	Crystal CS4237B audio controller
K	Intel PIIX4 ISA/IDE/USB controller



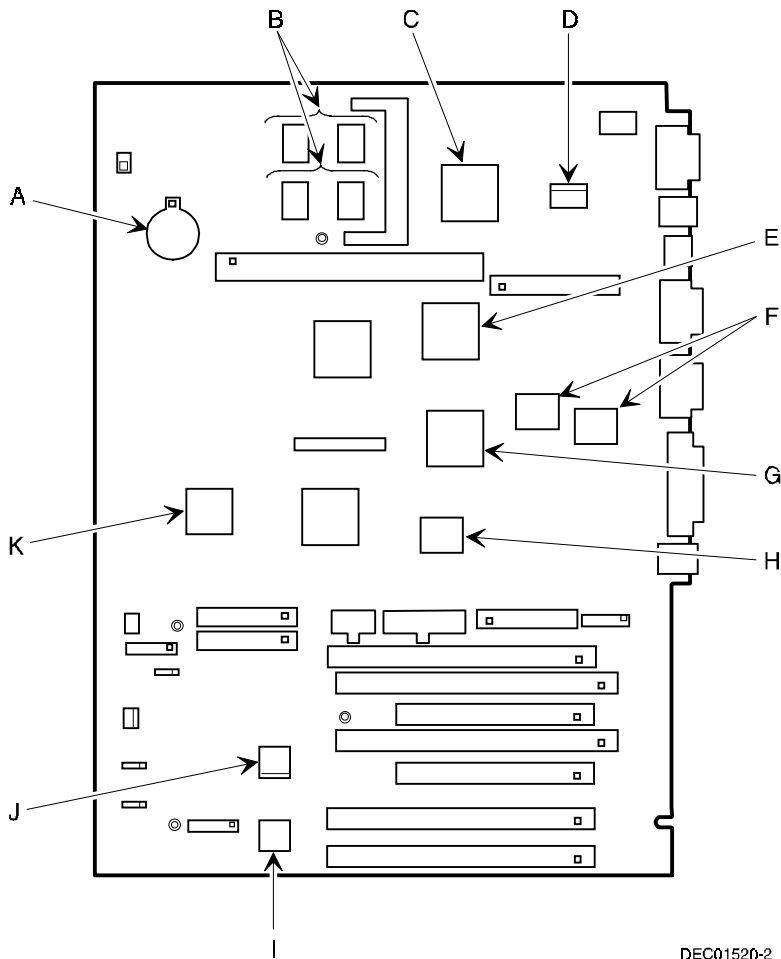

DEC01520-2

Figure 5-3. Main Logic Board Components

DIGITAL PERSONAL WORKSTATION

## Main Logic Board Connectors (Rear Panel)

Figure Legend	Connector
A	Video port
B	Keyboard and mouse ports
C	Two USB ports
D	Two serial ports
E	Parallel port
F	10/100Base-T network port



**NOTE:** Your workstation's video port is located on the PCI video expansion board that was factory installed into your workstation.

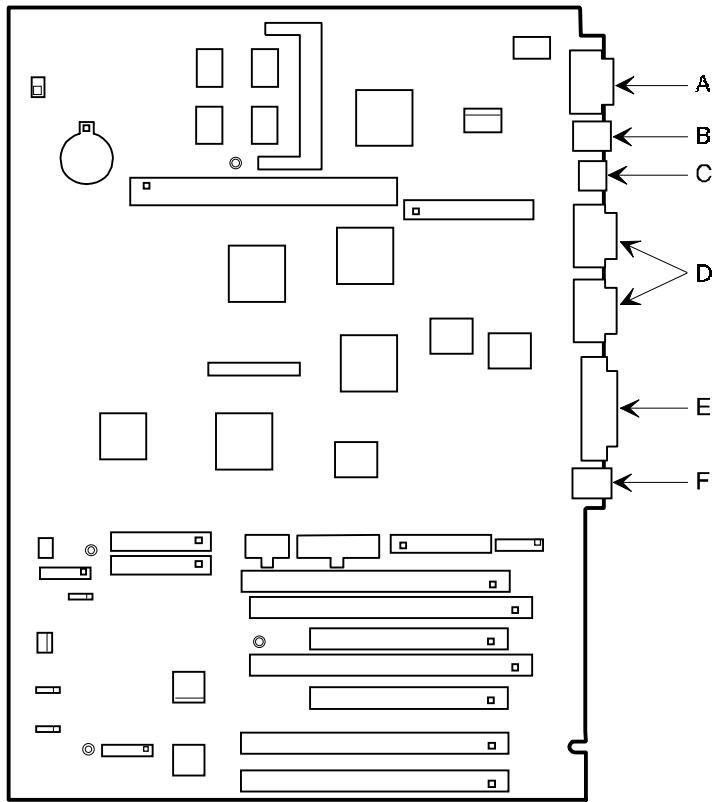

DEC01520-3

Figure 5-4. Main Logic Board Components (Rear Panel)

DIGITAL PERSONAL WORKSTATION

## Main Logic Board Feature Switch Settings



**STATIC SENSITIVE:** Static electricity collects on non-conductors such as paper, cloth, or plastic. A static discharge can be damaging even though you often cannot see or feel it. To prevent damage to the main logic board:

- Touch the metal frame of your workstation to discharge any static electricity.

Feature	Function	Setting	Description
Clear password	Enable Disable <sup>(1)</sup>	SW1-1, ON SW1-1, OFF <sup>(1)</sup>	If you forget your password, set this switch to ON and then restart the workstation. Then, set the switch to OFF again.
Recovery mode	Enable Disable <sup>(1)</sup>	SW1-2, ON SW1-2, OFF <sup>(1)</sup>	If your flash BIOS upgrade failed, set this switch to ON so you can boot your workstation from a Crisis Recovery diskette. Refer to the README.TXT provided with the flash BIOS upgrade.
Clear CMOS	Enable Disable <sup>(1)</sup>	SW1-3, ON SW1-3, OFF <sup>(1)</sup>	Clears CMOS of all BIOS setup information. Use the Enable setting when your workstation will not boot, and BIOS setup cannot be accessed due to configuration data corruption. This switch must be set back to Disable before rebooting your workstation.
Flash enable	Enable Disable <sup>(1)</sup>	SW1-4, ON SW1-4, OFF <sup>(1)</sup>	When disabled, prevents corruption or reprogramming of BIOS boot block data. Updating the BIOS boot block data is normally reserved for factory use only, unless instructed otherwise by your Service provider.

<sup>(1)</sup> Factory default



DEC01520-B

Figure 5-5. Main Logic Board Switch Locations

DIGITAL PERSONAL WORKSTATION

## Pentium II Processor Module Switch Settings

The following table lists the Pentium II processor module switch settings and factory default settings. Figure 5-6 shows the switch location.

<b>Frequency</b>	<b>SW1-1</b>	<b>SW1-2</b>	<b>SW1-3</b>	<b>SW1-4</b>
350 MHz	OFF	OFF	ON	ON
400 MHz	ON	ON	OFF	ON
450 MHz	OFF	ON	OFF	ON

OFF = open  
ON = close

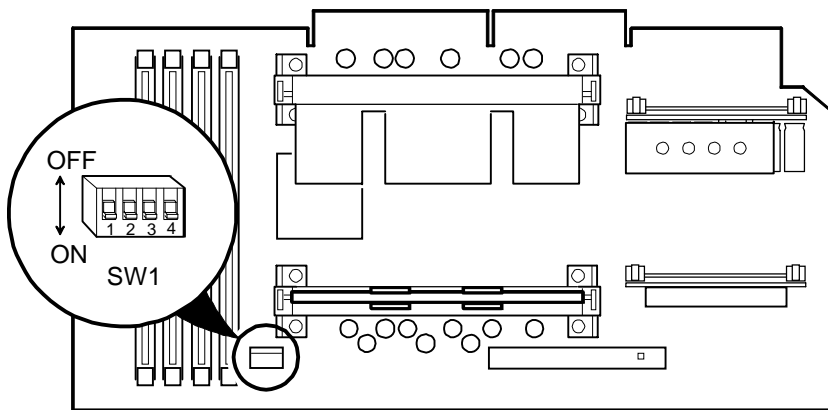

DEC01522-8

**Figure 5-6. Pentium II Processor Module Switch Locations**

## Adding Additional Workstation Memory

DIGITAL Personal Workstations come with at least 64 MB of workstation memory. DIGITAL Personal Workstations also contain four DIMM connectors. All four DIMM sockets (DIMM 1, DIMM 2, DIMM 3, and DIMM 4) accept single or dual sided DIMMs.

Install 168-pin DIMMs using 100 MHz (or faster), 64-bit SDRAMs, in 32 MB, 64 MB, 128 MB, and 256 MB memory module sizes, to expand workstation memory up to 1 GB.

At the time of publication, 256 MB DIMMs only come in the registered variety. Do not mix registered and unbuffered DIMMs on the same system. They will not work together.

Figure 5-7 shows the location of the four DIMM sockets.

Parts Replacement

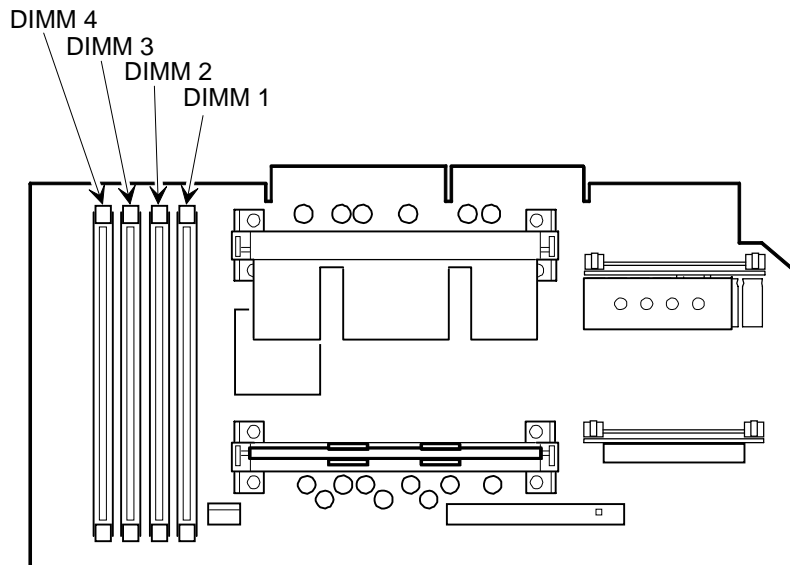

DEC01522-7

**Figure 5-7. DIMM Socket Locations**



## Adding Video Memory

When equipped with an integrated Permedia 2 graphics/video accelerator, the workstation includes 4 MB of SGRAM video memory on the main logic board. This can be upgraded by:

- Installing an optional 4 MB SGRAM daughter card on the main logic board
- Installing a 4 MB SGRAM daughter card on an optional NLX form factor AGP video expansion board

Figure 5-8 shows the location of the SGRAM socket on the main logic board and of the optional AGP video expansion card.

Parts Replacement

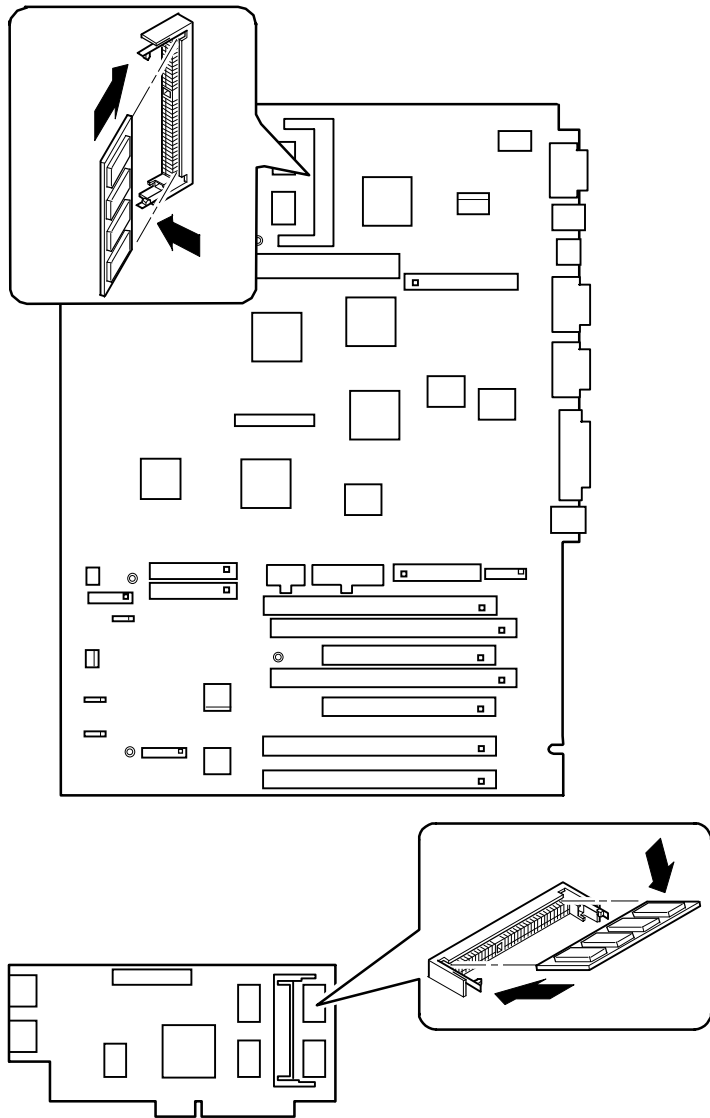

DEC01523

**Figure 5-8. Video Memory Socket Location**

## Removing and Replacing Components

The following sections provide removal and replacement procedures for the following DIGITAL Personal Workstation components:

- Main logic board
- DIMMs
- Battery
- Processor
- VRM
- Terminator Module
- Expansion boards
- Power supply
- Control panel
- Fans
- 3½-inch mass storage devices
- 5¼-inch mass storage devices

## Removing the Main Logic Board

1. Turn off your workstation and monitor.
2. Disconnect all external devices, ac power, and monitor power.
3. Remove the outside cover.
4. Disconnect all internal device cables and then tag them for identification.
5. Remove all expansion boards.
6. Remove the Pentium II processor module.
7. Remove the four screws from the expansion board area of the main logic board.
8. Carefully slide the main logic board towards the top and out of the chassis.



**NOTE:** If replacing the main logic board, it may be necessary to move other components such as video memory to the new main logic board.



**STATIC SENSITIVE:** Static electricity collects on non-conductors such as paper, cloth, or plastic. A static discharge can be damaging even though you often cannot see or feel it. To prevent damage to the main logic board:

- Touch the metal frame of your workstation to discharge any static electricity.
- Keep the main logic board away from non-conductors.

Parts Replacement

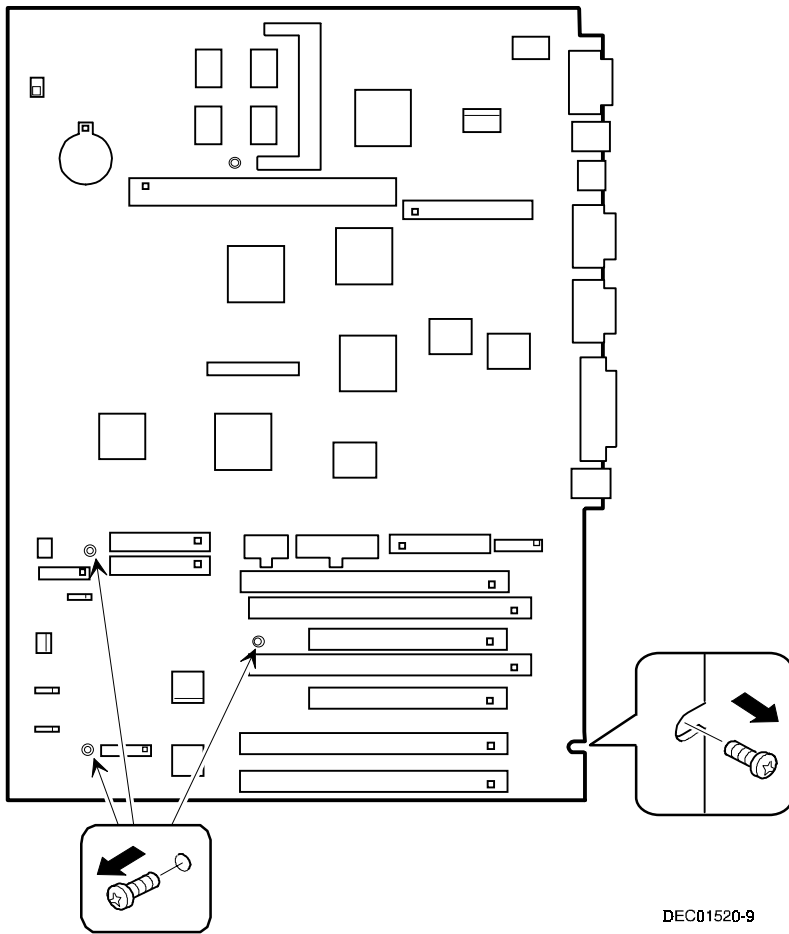

DIGITAL PERSONAL WORKSTATION

Figure 5-9. Removing the Main Logic Board

## Parts Replacement

### **Removing the DIMMs**

1. Turn off the workstation and monitor, and disconnect power from the workstation.
2. Remove the outside cover.
3. Press the DIMM retaining clips out.
4. Press the DIMM retaining clips out and pull the DIMM out of the socket.

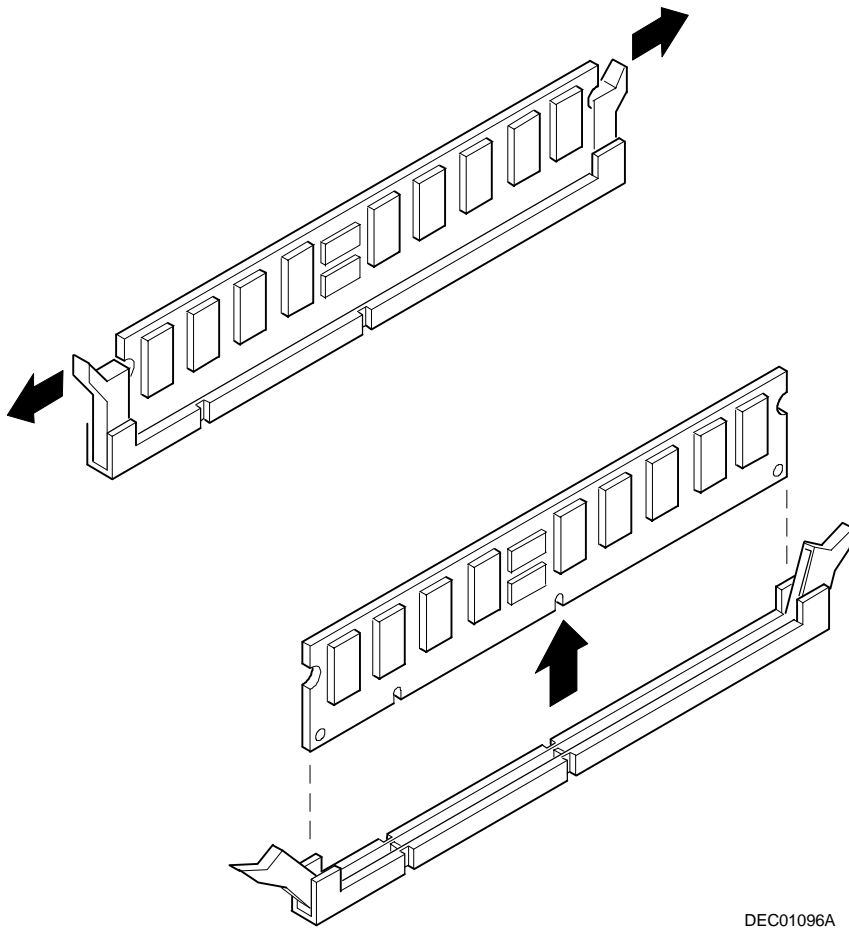

DEC01096A

Figure 5-10. Removing DIMMs

## Removing the Lithium Battery

1. Record workstation configuration settings using the BIOS Setup utility.
2. Turn off the workstation and monitor, disconnect power from the workstation.
3. Remove the outside cover.
4. Remove the Pentium II processor module.
5. Remove the old battery from the main logic board by pushing on the battery socket where it says PUSH, then sliding the battery out.



**WARNING:** There is a danger of battery explosion if a lithium battery is incorrectly replaced. To prevent damage to the workstation, be sure the + side faces up when installing a new battery. Also, be sure you replace the battery with either a DIGITAL (P/N 12-41474-05), Toshiba (P/N CR2032), or equivalent 3 V dc lithium battery.

Depending on the locality, the workstation's battery might be considered hazardous waste. Make sure you follow any state or local statute to properly dispose of the old battery.



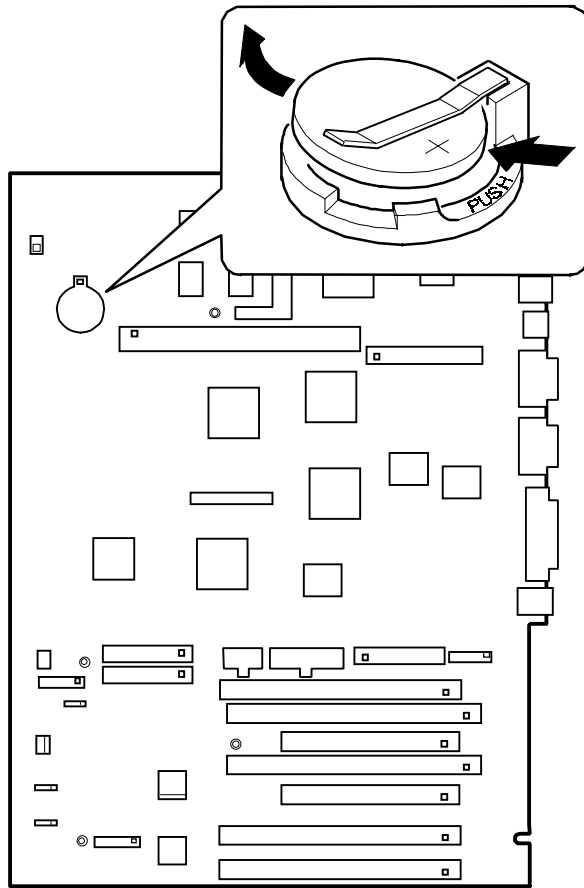

DEC01520-5

Figure 5-11. Removing the Lithium Battery

DIGITAL PERSONAL WORKSTATION

## Removing the Processor Module

1. Turn off the workstation, monitor, and then disconnect power from the workstation.
2. Remove the outside cover.
3. Remove the NLX form factor AGP graphics accelerator board (if there is one).
4. Pull out on the two plastic ejectors to release the Pentium II processor module from the main logic board.

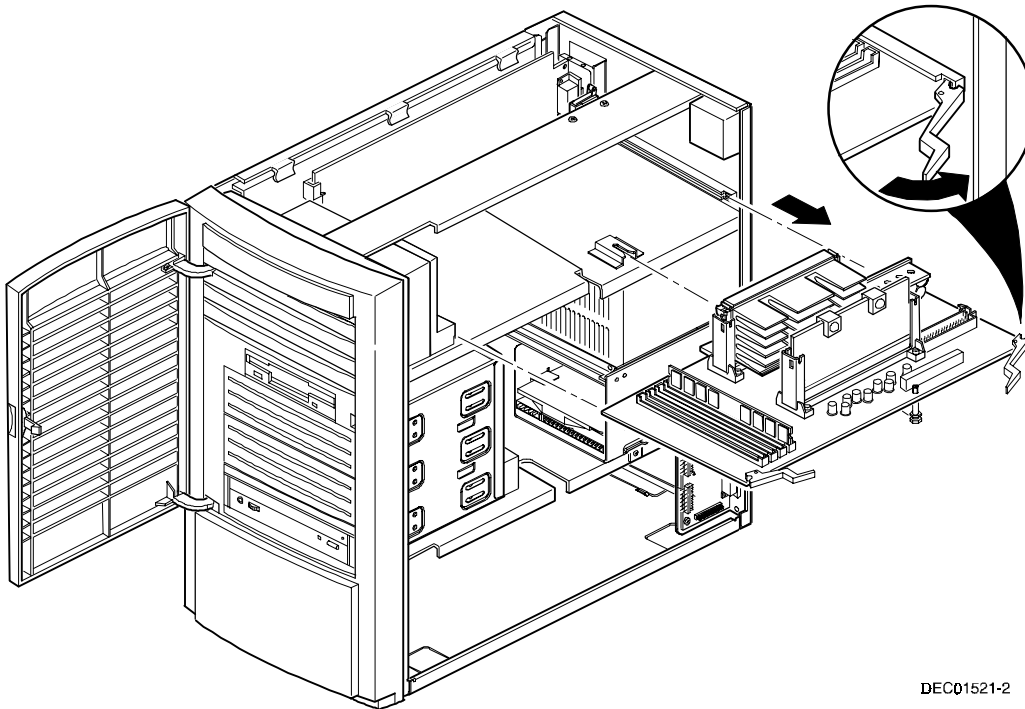

DEC01521-2

**Figure 5-12. Removing the Pentium II Processor Module**

## Removing the Voltage Regulator Module (VRM)

1. Turn off the workstation, monitor, and then disconnect power from the workstation.
2. Remove the outside cover.
3. Release the processor module from the main logic board.
4. Push the clips to release the VRM from the processor module.
5. Remove the VRM by pulling it straight up.

Parts Replacement

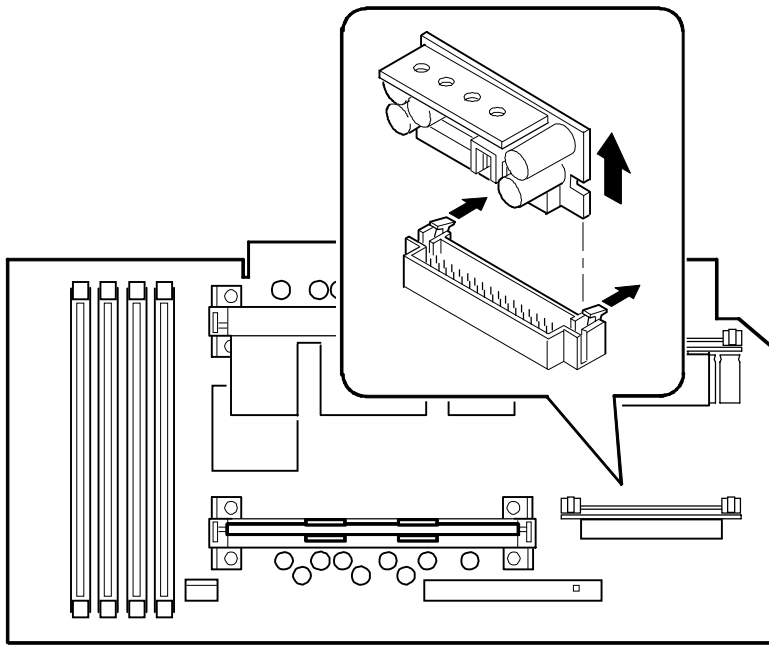

DEC01522-9

**Figure 5-13. Removing the VRM**

## Removing the Terminator Module

1. Turn off your workstation and monitor.
2. Disconnect all external devices, ac power, and monitor power.
3. Remove the outside cover.



**STATIC SENSITIVE:** Static electricity collects on non-conductors such as paper, cloth, or plastic. A static discharge can be damaging even though it often cannot be seen or felt. To prevent damage to the processor:

- Touch the metal frame of your workstation to discharge any static electricity.
  - Keep the processor away from non-conductors.
4. Release the processor module from the main logic board.
  5. Carefully grasp the terminator card by the plastic tab on the top and pull up.

Parts Replacement

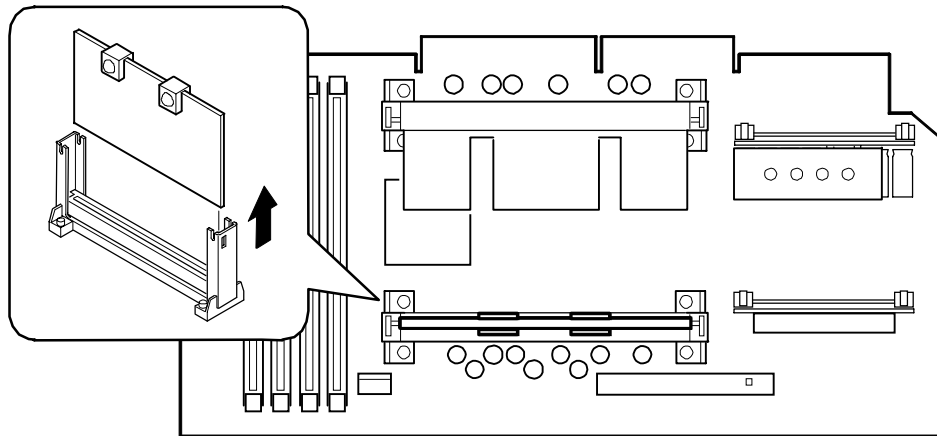

DEC01522-6

**Figure 5-14. Removing the Terminator Module**

## Removing the AGP Graphics Accelerator Board

1. Turn off the workstation, monitor, and then disconnect power from the workstation.
2. Remove the outside cover.
3. Remove the screw that secures the AGP graphics accelerator board to the chassis.
4. Gently pull the NLX form factor AGP graphics accelerator board from its socket on the Pentium II processor module.

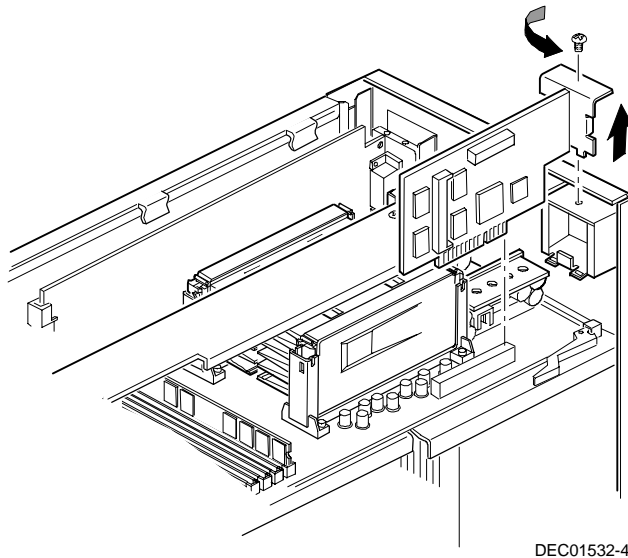

Figure 5-15. Removing an AGP Graphics Accelerator Expansion Board

## Removing Expansion Boards



**NOTE:** Do not remove the main logic board to remove an expansion board.

1. Turn off the workstation, monitor, and then disconnect power from the workstation.
2. Remove the outside cover.
3. Remove the rear audio adapter.
4. Remove screw.
5. Gently pull the expansion board from its socket.



Parts Replacement

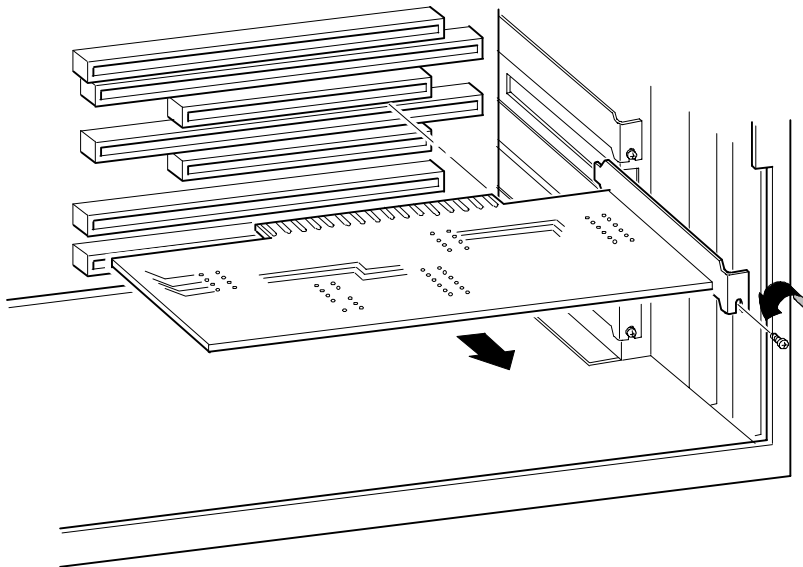

DEC01386-4

Figure 5-16. Removing Expansion Boards

DIGITAL PERSONAL WORKSTATION

## **Removing the Power Supply**

1. Turn off the workstation, monitor, and then disconnect power from the workstation.
2. Remove the outside cover.
3. Disconnect the power cable from the main logic board.
4. Disconnect all power cables from all devices.
5. Remove the processor board.
6. Remove the fan assembly.
7. Remove the top partition screw.
8. Remove the top partition by sliding to the left.
9. Remove the screws from the power supply.
10. Remove the power supply.

Parts Replacement

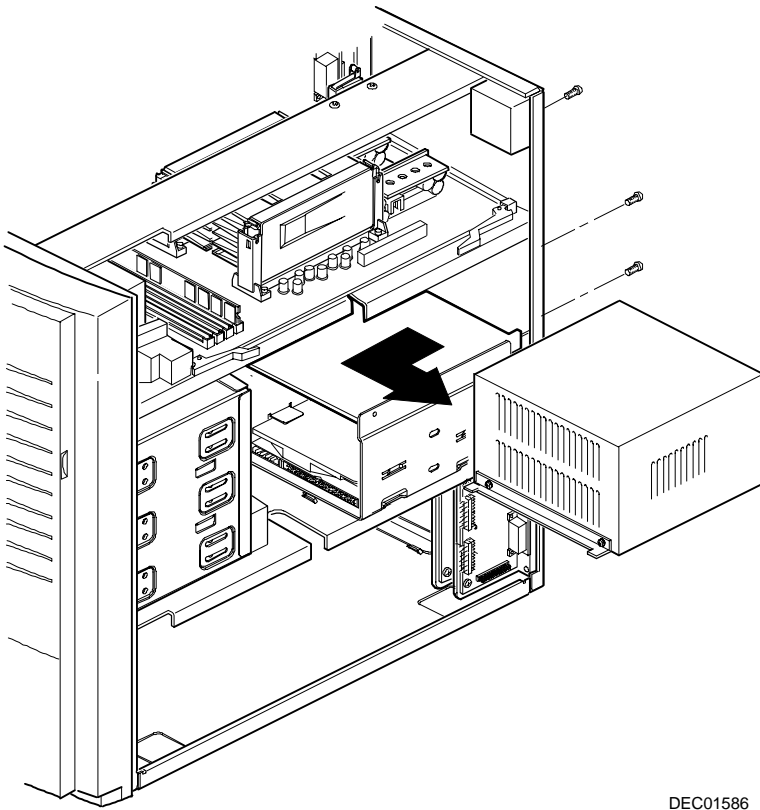

DEC01586

**Figure 5-17. Removing the Power Supply**

DIGITAL PERSONAL WORKSTATION

## Removing the Control Panel Assembly and Cable

1. Turn off the workstation, monitor, and then disconnect power from the workstation.
2. Remove the outside cover.
3. Remove front bezel.
4. Push in on the tabs to disengage the control panel assembly.
5. Disconnect the cables from the control panel assembly noting the following when you reconnect.
  - White and black is the reset switch.
  - White, black, and red is the power switch.
  - Red and black is hard disk drive activity LED.
  - Yellow and black is the power LED. It is on top of the hard disk drive indicator.
6. Slide the cables through the slots.

The cables and their attached switch or indicators are now inside the workstation.

7. Unplug the cable connection from the main logic board.
8. Rotate the speaker to remove it from the option card assembly.
9. Remove the control panel assembly cables from the workstation.

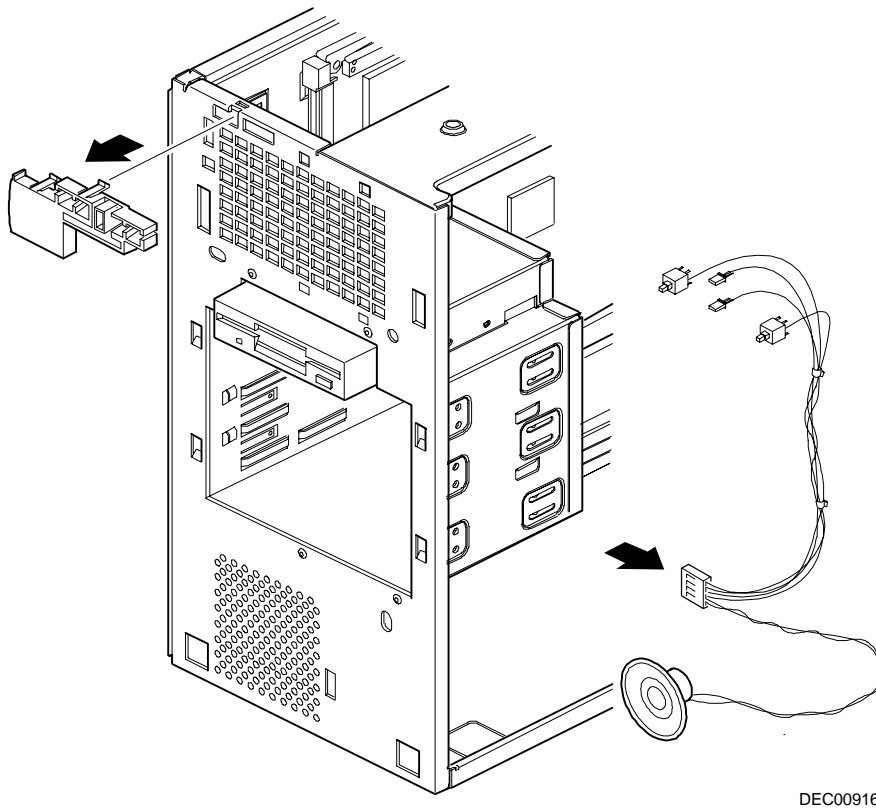

DEC00916

Figure 5-18. Removing the Control Panel Assembly and Cable

## Parts Replacement

### **Removing the Option Card Assembly**

1. Turn off the workstation, monitor, and then disconnect power from the workstation.
2. Remove the outside cover.
3. Push in on the tab to release the option card assembly.
4. Remove the option card assembly.

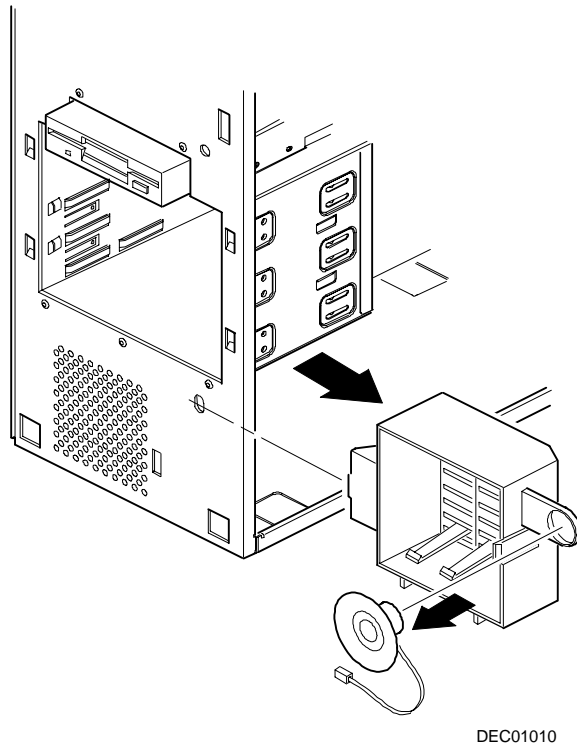

DEC01010

**Figure 5-19. Removing the Option Card Assembly**

## Removing the Wire Assembly, Headphone/Microphone

1. Turn off the workstation, monitor, and then disconnect power from the workstation.
2. Remove the outside cover.
3. Remove the front bezel.
4. Push in on the tabs to disengage the control panel assembly.

The headphone and microphone connections are on a card inside the control panel assembly. This card is attached to the cable.

5. Remove the headphone and microphone card from the control panel assembly.

Push down on the headphone and microphone card to release it from the tabs and then slide the card back.

6. Unplug the other side of the cable from the main logic board.
7. Slide the card through the appropriate front slot and then remove the headphone and microphone cable.



Parts Replacement

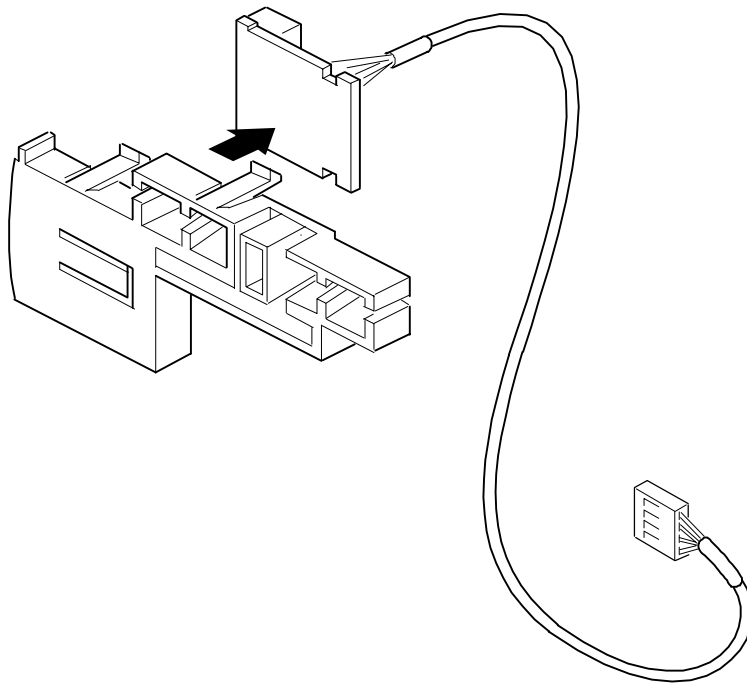

DEC00917

**Figure 5-20. Removing the Wire Assembly, Headphone/Microphone**

DIGITAL PERSONAL WORKSTATION

## **Removing the Front Bezel Door**

1. Open the front bezel door so that the door is open 90 degrees.
2. With one hand near the top hinge area (top inside edge of the door), apply pressure to the top of the top hinge assembly.
3. With your other hand on the outside of the top of the door, apply pressure on the top-front of the door, rotating the top of the door frame clockwise towards the center of the workstation.
4. Once the top hinge has cleared, lift the door from the bottom hinge point.

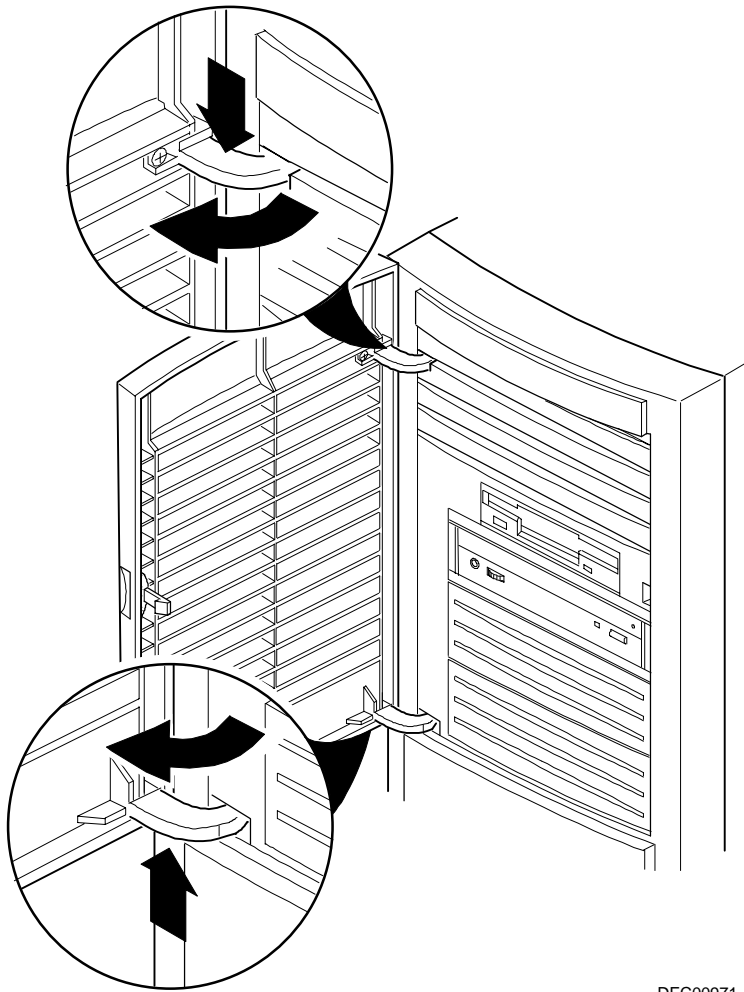

DEC00971

**Figure 5-21. Removing the Front Bezel Door**

DIGITAL PERSONAL WORKSTATION

## Removing the Front Bezel

1. Turn off the workstation, monitor, and then disconnect power from the workstation.
2. Remove the outside cover.
3. Remove the front bezel.
4. From the top of the workstation, looking down towards the bottom of the front of the chassis, there should be two tabs from the front bezel that hold the bezel in place and secure it to the chassis. Find both tabs (one on the left and one on the right).
5. Gently pull the top of the bezel approximately an inch away from the top of the chassis.
6. Gently but firmly, pull up on the bezel to detach the bottom bezel mounts.

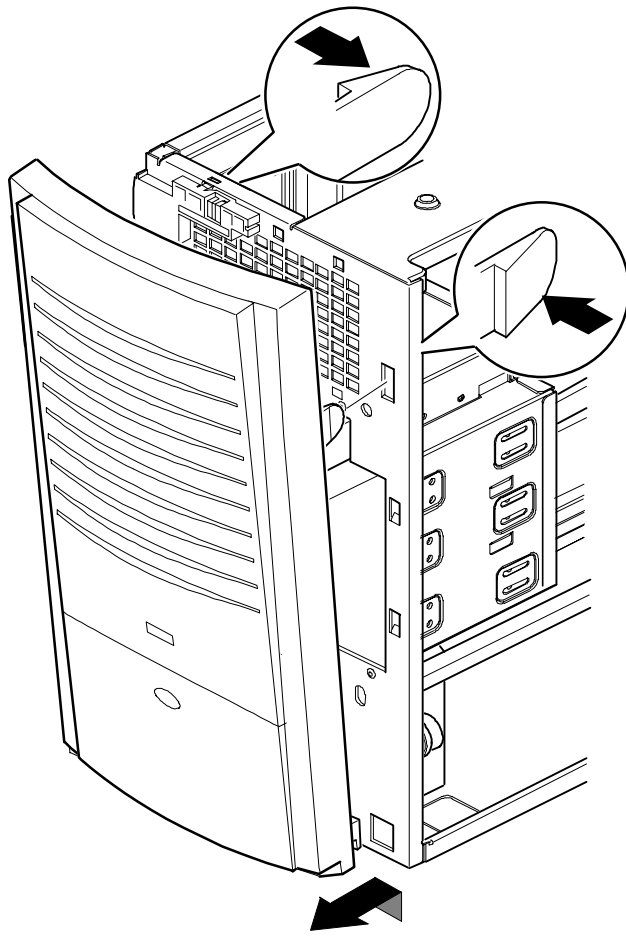

DEC00758-10

Figure 5-22. Removing the Front Bezel

DIGITAL PERSONAL WORKSTATION

## Removing a 3½-Inch Device from Front Bay

1. Turn off the workstation, monitor, and then disconnect power from the workstation.
1. Remove the outside cover.
2. Remove the front bezel.
3. Disconnect all power and data cables.
4. If necessary, remove the EMI shield.
5. Remove the two screws holding the drive to the bay.
6. Remove the 3½-inch device, which includes the rail and the brackets.
7. Remove the rail from the device.
8. Remove the brackets from the device.

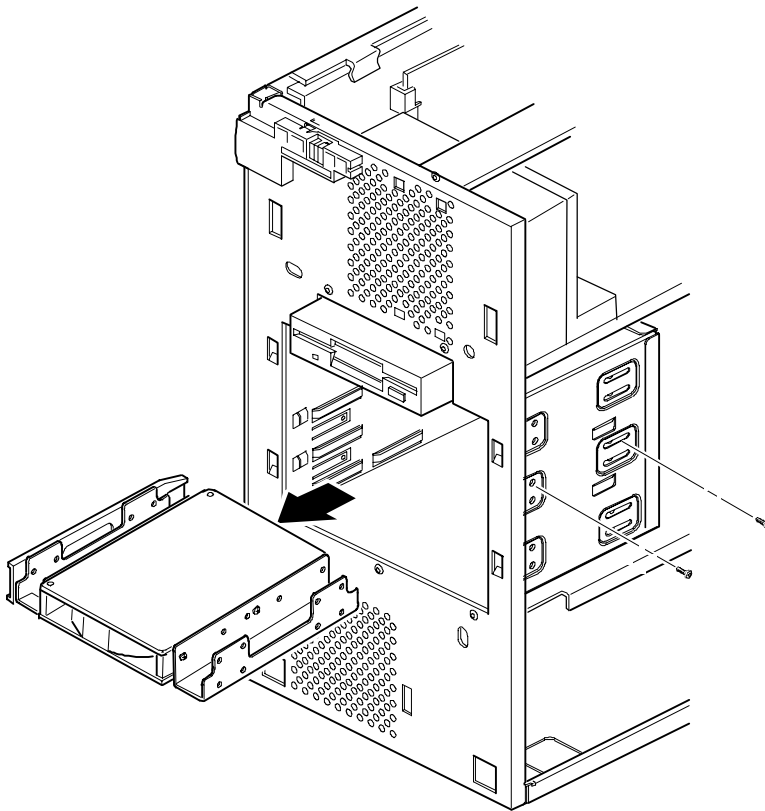

DEC01392-12

**Figure 5-23. Removing a 3½ -inch Device from the Front Bay**

DIGITAL PERSONAL WORKSTATION

## Removing a 5¼-Inch Device

1. Turn off the workstation, monitor, and then disconnect power from the workstation.
2. Remove the outside cover.
3. Remove the front bezel.
4. Disconnect all power and data cables.
5. If necessary, remove the EMI shield.
6. Remove the two screws holding the drive to the bay.
7. Remove the 5¼-inch device, which includes the rail.
8. Remove the rail from the device.



Parts Replacement

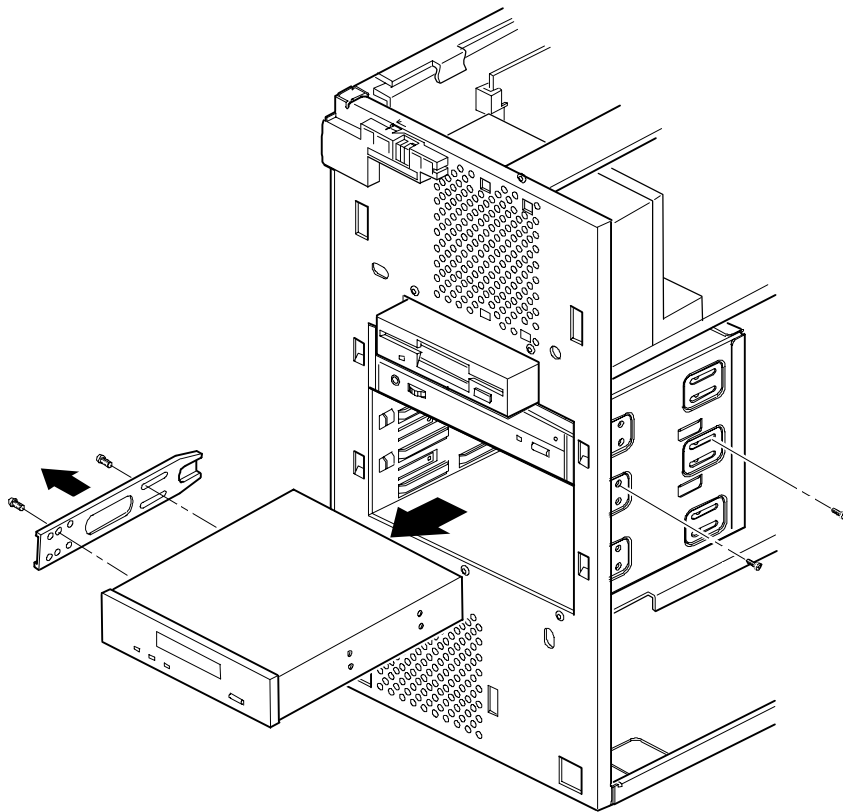

DEC01392-13

**Figure 5-24. Removing a 5 1/4-Inch Device**

DIGITAL PERSONAL WORKSTATION

## Removing an Internal 3½-Inch Device

1. Turn off the workstation, monitor, and then disconnect power from the workstation.
2. Remove the outside cover.
3. Disconnect all power and data cables.
4. Remove the two screws securing the drive bay to the chassis.
5. Swing the device bay away from the chassis.
6. Remove the screws from the drive bay.
7. Remove the 3½-inch device.

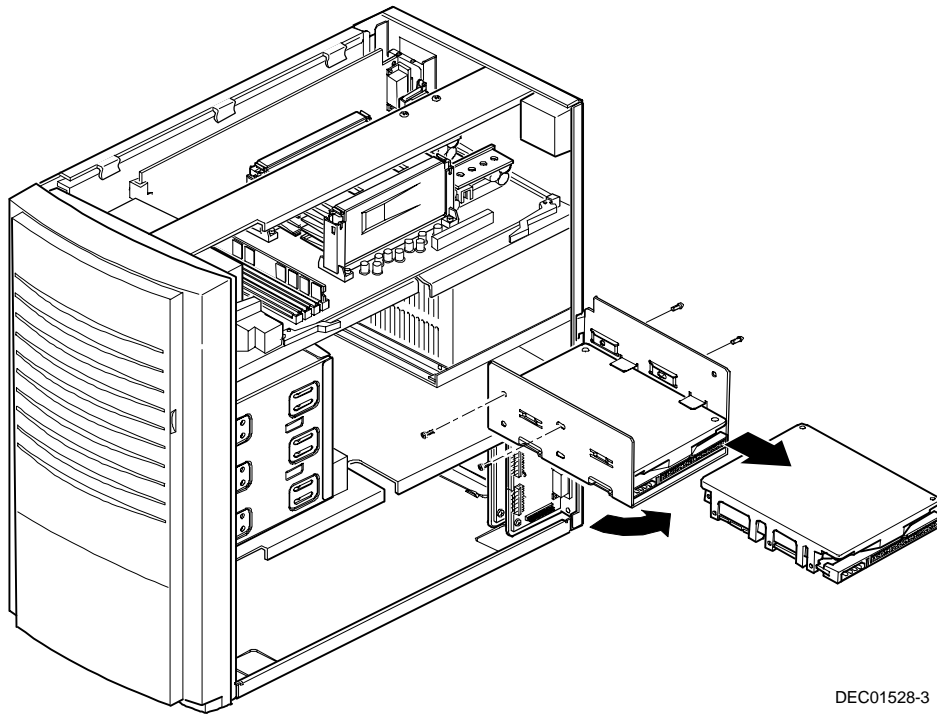

DEC01528-3

**Figure 5-25. Removing an Internal 3½-Inch Device**

## IDE Drive Connections

Figure Legend	IDE Drive Component
A	Main logic board IDE drive connection (primary)
B	Power connections
C	Power supply
D	Primary IDE hard disk drive
E	Primary IDE hard disk drive connections
F	Main logic board IDE drive connection (secondary)
G	Secondary IDE hard disk drive connections
H <sup>(1)</sup>	CD-ROM drive

<sup>(1)</sup> The CD-ROM drive is connected to the secondary IDE port and configured as a master drive.



**NOTE:** When installing a CD-ROM drive, make sure that the hard disk drives are on one channel and the CD-ROM drive is on another. If you install a CD-ROM drive on the secondary/master channel and a hard disk drive on the secondary/slave channel, you might get a POST error and BIOS autodetect error. In addition, the hard disk drive on the secondary channel will be slowed to the same speed as the CD-ROM drive, resulting in poor hard disk drive performance and speed.

Parts Replacement

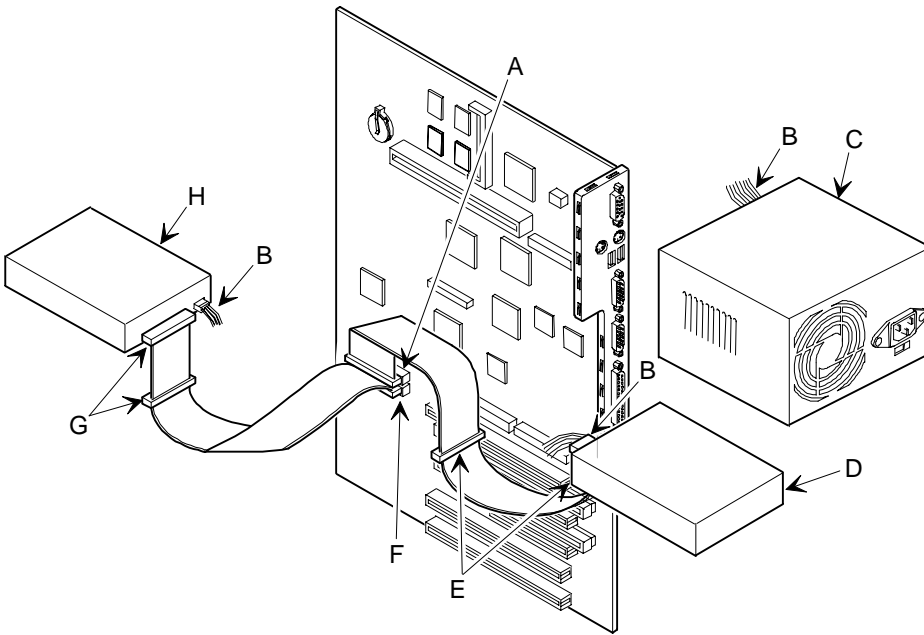

DEC01530

Figure 5-26. IDE Device Data Cable Connections

DIGITAL PERSONAL WORKSTATION

## SCSI Drive Connections

<b>Figure Legend</b>	<b>Component</b>
A	CD-ROM drive (or other SCSI device)
B	Power connection
C	Single-ended active terminator
D	SCSI connectors
E	SCSI hard disk drive
F	SCSI controller connector (68-pin)
G	Power supply

Parts Replacement

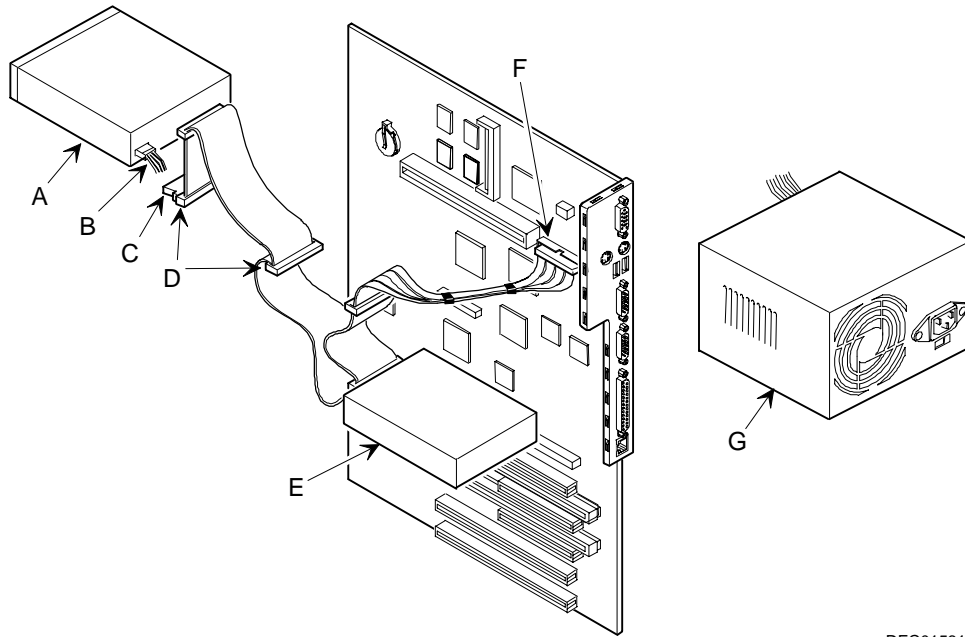

DEC01531

Figure 5-27. SCSI Device Data Cable Connections

DIGITAL PERSONAL WORKSTATION

## Parts Replacement

### **Removing the Diskette Drive**

1. Turn off the workstation, monitor, and then disconnect power from the workstation.
2. Remove the outside cover.
3. Remove the front bezel.
4. Remove all power and data cables from the diskette drive.
5. Remove the screws.
6. Remove the diskette drive.



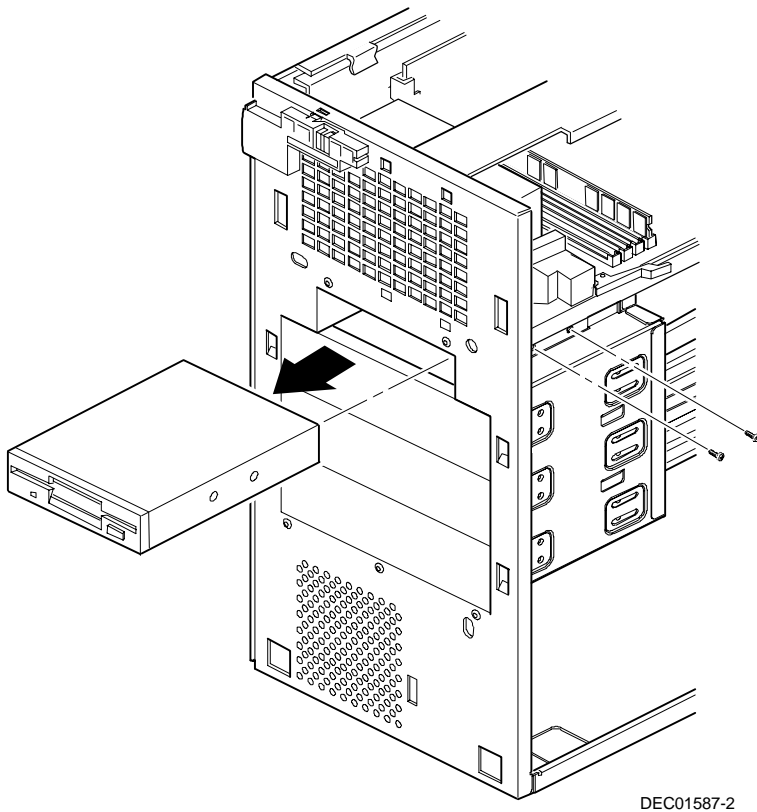
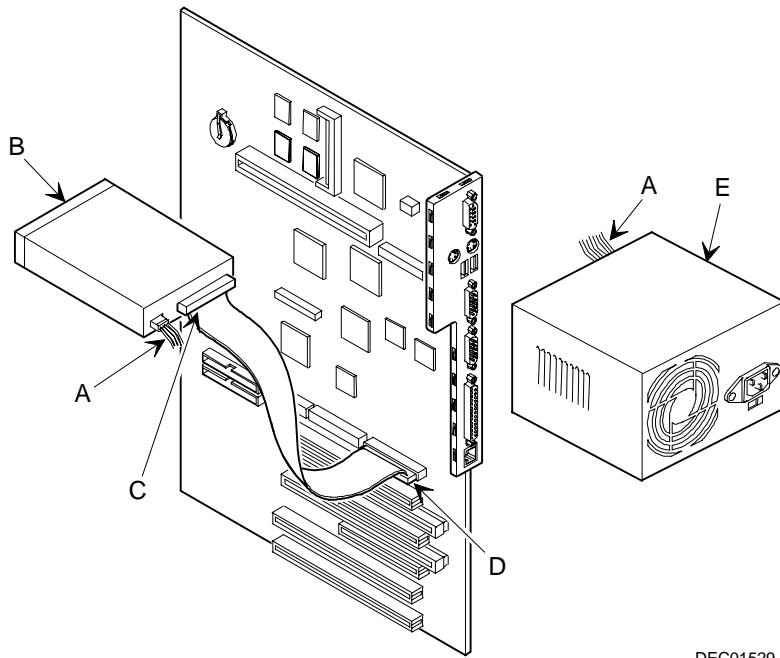

**Figure 5-28. Removing the Diskette Drive**

DIGITAL PERSONAL WORKSTATION

## Diskette Drive Connections

Figure Legend	Diskette Drive Component
A	Power connection
B	Diskette drive
C	Diskette drive connections
D	Diskette drive connection
E	Power supply



DEC01529

Figure 5-29. Diskette Device Data Cable Connections

Parts Replacement

# Device Mapping **6**

---

## Introduction

This chapter provides a series of tables listing mapping and address information related to workstation memory.

Your workstation's memory and address locations are allocated at the factory to operate within a standard PC environment. However, due to the number of optional devices and/or expansion boards that are available, sometimes memory and address locations need to be changed. For example, some network expansion boards require a specific memory location. If that location is already allocated, a memory conflict results and the expansion board will not operate as expected. Note that some memory, I/O and interrupt locations can be changed using the BIOS Setup utility.



**CAUTION:** Before changing any memory or address location, refer to the documentation supplied with the optional device, expansion board, or software application and make sure adequate information is available. If not, contact the option or software manufacturer for further information.

## Device Mapping

### Full Range Processor Memory Address Map

Range	Function	Size
0 to 9FFFFh	Base memory	640 KB
A0000h to BFFFFh	Video RAM	128 KB
C0000h to C7FFFh	Video BIOS	32 KB
C8000h to CAFFFh	SCSI BIOS	12 KB
CB000h to DFFFFh	BIOS extension ROM (AT bus used)	84 KB
E0000h to FFFFFh	PnP BIOS/APM BIOS	128 KB
100000h to 3FFFFFFFh	Extended memory	1023 MB

## I/O Address Map

Range (hexadecimal)	Function
000 - 00F	DMA controller one
020 - 021	Interrupt controller one
022-03F	Programming chip select
040 - 043	Interval timer
060 - 06F	Keyboard controller
070 - 07F	Real-Time Clock (RTC), NMI
080 - 08F	DMA page register
0A0 - 0A1	Interrupt controller two
0C0 - 0CF	DMA controller two
0F0	Clear math co-processor busy
0F1	Reset math co-processor
0F8 - 0FF	Math co-processor
0FF0	Programming chip select
170 - 177	Secondary IDE controller
1F0 - 1F7	Primary IDE controller
200 - 207	Audio, Joystick
220 - 22F	Audio Sound Blaster Pro compatible
278 - 27A	LPT2
2E8 - 2EF	COM4

*continued*

## Device Mapping

<b>Range (hexadecimal)</b>	<b>Function</b>
2F8 - 2FF	COM2
300 - 301	Audio, MP401
378 - 37A	LPT1
388 - 38B	Audio, FM music synthesizer
3BC - 3BE	LPT3
3E8 - 3EF	COM3
3F0 - 3F7	Diskette (floppy disk) controller
3F6 - 3F7	Primary/secondary IDE controller (alt status, device address)
3F8 - 3FF	COM1
4D0	Edge/level control register - INTCNTRL1
4D1	Edge/level control register - INTCNTRL2
CF8 - CFF	PCI configure space control register



Device Mapping

DIGITAL PERSONAL WORKSTATION

**Service Notes**

---

**A**

DIGITAL PERSONAL WORKSTATION

Service Notes

Service Notes

DIGITAL PERSONAL WORKSTATION

Service Notes