



PCXCV-Cx, -Dx Auto-Scanning Color Monitor

Installation Guide

Order Number: ER-XCVCX-IM. A01

Digital Equipment Corporation

November 1996

The information in this document is subject to change without notice and should not be construed as a commitment by Digital Equipment Corporation. Restricted Rights: Use, duplication, or disclosure by the U.S. Government is subject to restrictions as set forth in subparagraph (c) (1) (ii) of the Rights in Technical Data and Computer Software clause at DFARS 252.227-7013.

Note: This equipment has been tested and found to comply with the limits for a Class B digital device, pursuant to Part 15 of the FCC rules. These limits are designed to provide reasonable protection against harmful interference in a residential installation. Any changes or modification made to this equipment may void the user's authority to operate this equipment.

This equipment generates, uses, and can radiate radio frequency energy and, if not installed and used in accordance with the instructions, may cause harmful interference to radio and television reception; however, there is no guarantee that interference will not occur in a particular installation. If this equipment does cause harmful interference to radio or television reception, which can be determined by turning the equipment off and on, the user is encouraged to try to correct the interference by one of the following measures:

- Re-orient or relocate the receiving antenna.
- Increase the separation between the equipment and the receiver.
- Connect the equipment to an outlet on a circuit different from that to which the receiver is connected.
- Consult the dealer or an experienced radio/TV technician for help.

DO NOT attempt to modify this equipment. If modified, the FCC may void your authority to operate this equipment.

VCCI Class 2 - Japan

Canadian Department of Communications Statement

This Class B digital apparatus meets all requirements of the Canadian Interference Causing Equipment Regulations.

DEC and the DIGITAL logo are trademarks of Digital Equipment Corporation. IBM is a registered trademark of International Business Machines Corporation. VESA is a registered trademark of the Video Electronics Standards Association. All other trademarks and registered trademarks are the property of their respective holders.

As an ENERGY STAR™ partner, Digital Equipment Corporation has determined that this product meets the ENERGY STAR™ guidelines for energy efficiency.

© 1996 Digital Equipment Corporation.
All Rights Reserved.

Contents

Introduction

Overview	1
DDC (Display Data Channel)	2

Installation

Installation/Operating Guidelines	2
Tilt/Swivel Stand Installation	3
Monitor Installation	4

Servicing

Cleaning the Monitor	7
Maintenance and Troubleshooting.....	7

Specifications

Display Modes.....	8
Monitor Specifications	9
Power Management System.....	10
Environment	12

Tables

Table 1 User Controls and Functions	6
Table 2 Identifying and Correcting Problems	8
Table 3 Display Modes and Addressability	8
Table 4 Monitor Specifications.....	9
Table 5 Power Saving States	10

Figures

Figure 1 PCXCV-Cx, -Dx Color Monitor.....	1
Figure 2 Tilt/Swivel Stand Installation	3
Figure 3 PCXCV-Cx, -Dx Monitor (Rear View).....	4
Figure 4 Control Panel, LED, and Power Switch.....	5

Audience

This guide is intended for user's who wish to install the monitor.

Conventions

The following conventions are used in this document:

Convention	Meaning
Note	Provides general information.
Caution	Provides information to prevent damage to equipment.
Warning	Provides information to prevent injury.

Introduction

Overview

The PCXCV-Cx, -Dx monitors are color monitors with high resolution and auto-scanning, compatible with VGA, SVGA, and 1024 x 768 modes. The PCXCV-Cx, -Dx monitors offer the following features:

- 1024 horizontal x 768 vertical non-interlaced resolution
- 85 Hz refresh with SVGA 800 x 600 mode
- Power Management system that exceeds EPA ENERGY STAR™ requirements for saving energy.
- VESA Data Display Channel - DDC1/2b
- Complies with Swedish MPR2 standards for low magnetic emissions
- Anti-glare screen with anti-static coating
- Tilt-swivel base

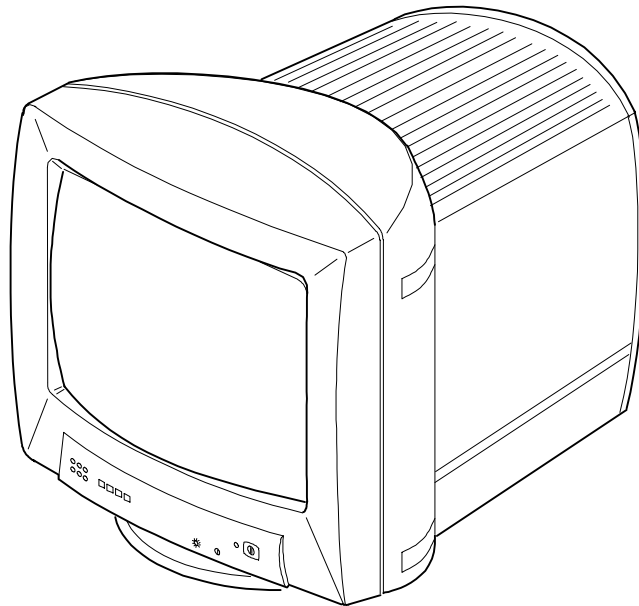

DEC01073

Figure 1. PCXCV-Cx, -Dx Color Monitor

DDC (Display Data Channel)

DDC is a communication channel over which the monitor automatically informs the host system about its capabilities. DDC uses formerly unconnected signal pins in the 15-pin VGA connector. The system performs the “Plug ‘n Play” feature if both the monitor and the host implement DDC protocol.

Installation

Installation/Operating Guidelines

Observe the following basic rules for installation and use.

Do . . .

- Use the power cord from the PC country kit, which is UL-, CSA-, and VDE-approved.
- Turn the monitor off when not being used for an extended period of time, or use Power Management if applicable.

Do Not . . .

- Overload the ac outlet.
- Move the monitor on a stand over carpet or thresholds.
- Push objects into the monitor’s openings.
- Add accessories that are not designed for this monitor.
- Operate the monitor near water or in a damp environment, which could cause an electrical hazard.
- Operate the monitor near magnets, motor devices, transformers, high power lines, or large steel pillars, which can cause distortion in the picture.
- Obstruct the ventilation openings in the monitor’s cabinet, such as placing the monitor on a rug or within an enclosure.
- Place the monitor near a radiator or heat source.

Tilt/Swivel Stand Installation

To install the stand:

1. Insert the hooks on the stand into the slots in the bottom of the monitor.
2. Apply pressure near the latch so it is secure. (To remove the stand, pull on the latch.)

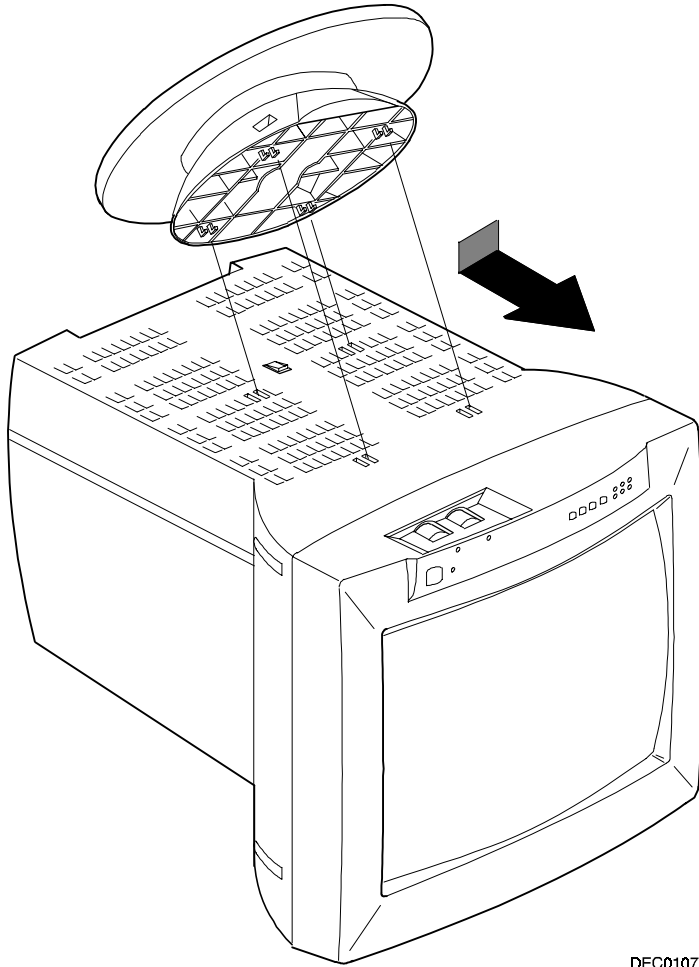

DEC01074

Figure 2. Tilt/Swivel Stand Installation

Monitor Installation

To connect the monitor:

1. Make sure the power to the monitor and the computer is off.
2. Connect the monitor's signal cable to the back of the monitor (1) and to the 15-pin interface connector on the High Resolution Graphic Video Adapter on the back of the computer.
3. Plug the ac power cord to the monitor (2), then to a properly-grounded ac electrical outlet.

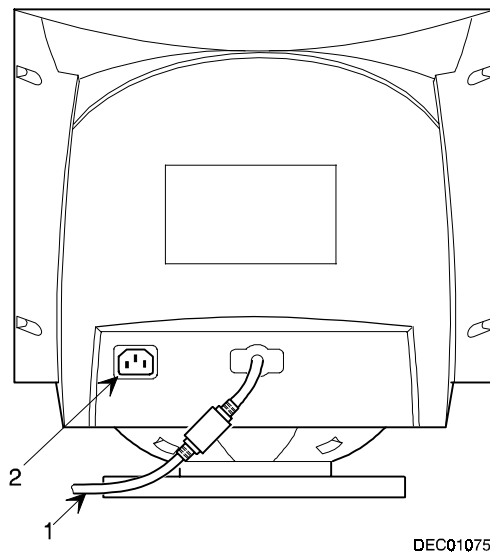

Figure 3. PCXCV-Cx, -Dx Monitor (Rear View)

Turn On Power to Monitor

Push the power switch button (1) to turn on the monitor. The power indicator LED (2) to the left of the switch should light green. The control panel (3) is described in Table 1.

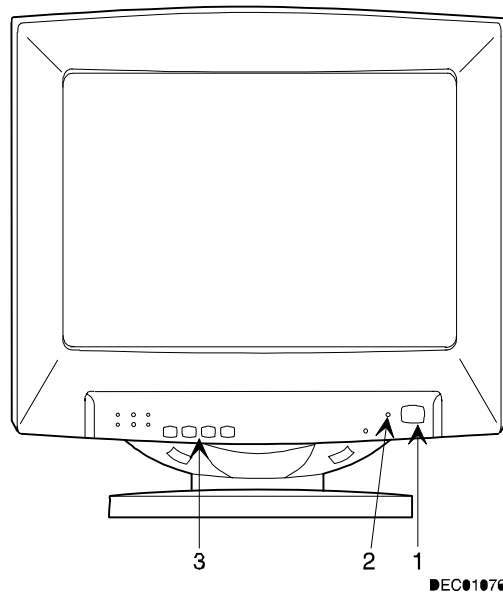









Figure 4. Control Panel, LED, and Power Switch

Table 1. User Controls and Functions

Item	Icon	Name	Function
1	◀ ▶	Select	Select adjustment
	+, -	Plus, Minus	Changes the setting of the selected function.
		Recall	Pressing the + and the - buttons simultaneously returns the settings of the standard six display modes to their factory values.
		V-Center	Adjusts the vertical centering.
		V-Size	Adjusts the vertical size.
		H-Center	Adjusts the horizontal centering.
		H-Size	Adjusts the horizontal size.
		Pincushion	Corrects the bowing in or out.
		Trapezoid	Corrects the geometric distortion.
		Contrast	Adjusts white level for comfortable viewing.
		Brightness	Adjusts black level for comfortable viewing.
2		Power/DPMS indicator	Identifies the power state of the monitor.
3		Power switch	Turns the monitor on and off.

Note: Once the adjustments are made, they are stored in memory even if the power is removed.

Servicing

Cleaning the Monitor

To clean the monitor:

1. Unplug the monitor.
2. Clean the monitor with a soft, slightly damp cloth. **Do not** use an aerosol cleaner directly on the screen.

CAUTION

Do not use benzene, thinner, or any volatile substance to clean the monitor, as these products may discolor the monitor's cabinet. Likewise, do not place rubber or vinyl on the monitor.

Maintenance and Troubleshooting

Identifying and Correcting Problems

The following can be sources of problems:

- Communications cables
- Host system
- Nearby power or electrical sources

Troubleshooting Table

Use Table 2 to identify and correct any problem area.

Table 2. Identifying and Correcting Problems

Symptom	Possible Cause	Suggested Solution
Display does not appear.	Brightness or contrast control is set too low. Power Management feature is active in the off state. There is no power.	Increase the brightness and contrast control setting to suit you. Press any key and allow 20 seconds for monitor to warm up. Check the power cord. Use another ac outlet.
Video display has moving dots and distorted lines. The display rolls or flickers.	There is electromagnetic interference.	Move any electromagnetic device, such as a fan or motor, away from the monitor or move the monitor.

Specifications

Display Modes

The monitor has six display modes that are preset to popular video modes, described in Table 3, and 12 user-adjustable modes.

Table 3. Display Modes and Addressability

Mode	Display Mode	Horizontal Frequency (KHz)	Vertical Frequency (Hz)	H Sync	V Sync
1	DOS, 720 x 400	31.47	70.08	-	+
2	VGA, 640 x 480	31.47	59.94	-	-
3	VGA, 640 x 480	43.27	85.01	-	-
4	SVGA, 800 x 600	37.88	60.32	+	+
5	SVGA, 800 x 600	53.67	85.06	+	+
6	1024 x 768	48.36	60.00	-	-

Monitor Specifications

Table 4. Monitor Specifications

Monitor	PCXCV-Cx	PCXCV-Dx
Diagonal	36.6 cm (14 in)	38 cm (15 in)
Viewable area	34 cm (13.4 in)	35 cm (13.8 in)
Active Area Pre-adjusted	25.1 x 18.5 cm (9.84 in x 7.28 in)	26.1 x 19.0 cm (10.2 x 7.5 in)
Height	36.2 cm (14.25 in), includes tilt/swivel base	38.3 cm (15 in)
Width	35.2 cm (13.9 in)	36.0 cm (14.2 in)
Depth	39.7 cm (15.6 in)	39.5 cm (15.6 in)
Swivel	±45°	±45°
Tilt	-5° to +13°	-5° to +13°
Weight	10.5 Kg (23.1 lb)	13.3 Kg (29.3 lb)
Video Signal	0.7V p-p R, G, B color; separate Sync (positive or negative); 75Ω TTL	
Horizontal Scan Rate	30 - 54 KHz	
Vertical Refresh Rate	50 - 90 Hz	
Connector	15-pin D-sub	
Power input	100 - 240 Vac, 1.5 amp maximum, 50/60 Hz.	
Environment		
Operating Temperature	10 - 40°C	
Humidity	10 - 90% relative humidity (noncondensing)	

Power Management System

The monitor has three power-saving states indicated by the LED on the front panel. For proper operation of this Power Management System, make sure that the monitor signal cable is connected to the host system and that the host is On.

Table 5. Power Saving States

LED	State	Power Consumption (Watts)*	Recovery Time
Green (Normal)	On	85 (max)	n/a
Amber	Standby or Suspend	< 15	3 s
Amber	Off	< 8	15 s

*These power-saving states exceed the Environmental Protection Agency (EPA) Energy Star requirements using the Video Electronics Standards Association (VESA) methodology for Display Power Management Signals.

Environment

This monitor has been designed and manufactured to minimize the impact to the environment.

Acoustic Levels

Preliminary declared values per ISO 9296 and ISO 7779:

	Sound Power Level ¹		Sound Pressure Level ²	
	L _{Wad} B		L _{pAm} dBA	
	Idle	Operate	Idle	Operate
PCXCV-Cx, -Dx	N/A	3.2	N/A	24

¹ 1 B = 10 dBA

² Operator position

Asbestos

This monitor does not use asbestos in any form.

Flame Retardants

The enclosures do not contain polybrominated diphenylether (PBDE) as a flame retardant additive; therefore, they do not emit toxic dibenzofuran and dibenzodioxin gases.

Ozone Depleting Substances (ODS)

These monitors are in full compliance with the labeling requirements in the U.S. Clean Air Act Amendments of 1990. It does not contain, nor is it manufactured with, a Class 1 ODS, as defined in Title VI section 611 of this act.

PVC

The plastic enclosures are not made of rigid PVC. The material has a non-halogenated, flame-retardant system and is cadmium free.

Recyclable Material

The packaging material can be recycled, or you can save it to return the monitor to a service center for repair or disposal.

Monitor Disposal

WARNING

If you need to dispose of a monitor, ask a qualified service representative for the proper procedure. Improper disposal could result in personal injury from implosion.
